

TC120/TC110 Universal Counters USER'S MANUAL

YOKOGAWA ◆

TC120/TC110 Universal Counters

YOKOGAWA ◆
Yokogawa Electric Corporation

IM 704111-01E
2nd Edition

Foreword

Thank you for buying a Synthesized Function Generator in the TC100 Series(*). This User's Manual contains useful information regarding the functions, operation and maintenance of the instrument in the TC100 Series. Read it thoroughly to acquaint yourself with the equipment to benefit the most from it. We suggest that you keep this manual near the equipment for quick reference whenever a question arises.

- TC100 Series refers to TC110 (without channel C input) and TC120 (with channel C input).

Notes

- The contents of this manual are subject to change without prior notice due to improvement of performance, function, etc.
- This manual has been prepared carefully and should be explicit and straightforward. If you should find a question or an error, however, please address your concern to a Yokogawa representative near you for our attention.
- It is prohibited by law to reprint or reproduce this manual in part or in whole without a written approval of the manufacturer.
- IBM is a registered trademark of International Business Machines Corporation.
- PC/AT is a registered trademark of International Business Machines Corporation.
- PC-9800 Series is a product of Nippon Electric Co., Ltd.

Version

- 1st edition : March 1994
- 2nd edition : February 1996

Safety Precautions

The TC100 Series instrument is a Safety Class I instrument (provided with terminal for protective earthing).

The following general safety precautions must be observed during all phases of operation, service, and repair of this instrument. Failure to comply with these precautions or with specific WARNINGS given elsewhere in this manual violates safety standards of design, manufacture, and intended use of the instrument.

YOKOGAWA Electric Corporation assumes no liability for the customer's failure to comply with these requirements.

General definitions of safety symbols used on equipment and in manuals



Explanation: To avoid injury, death of personnel or damage to the instrument, the operator must refer to an explanation in the instruction manual.

WARNING

A **WARNING** sign denotes a hazard. It calls attention to a procedure, practice, condition or the like, which, if not correctly performed or adhered to, could result in injury or death of personnel.

CAUTION

A **CAUTION** sign denotes a hazard. It calls attention to a procedure, practice, condition or the like, which, if not correctly performed or adhered to, could result in damage to or destruction of part of the product.

The numbers at some of the below mentioned warnings and cautions correspond to the numbers at warnings and cautions used throughout this manual.

WARNING

Power Supply

Ensure the source voltage matches the voltage of the power supply before turning on the power.

Protective Grounding

Make sure to connect the protective grounding to prevent an electric shock before turning on the power.

Necessity of Protective Grounding

Never cut off the internal or external protective grounding wire or disconnect the wiring of protective grounding terminal. Doing so poses a potential shock hazard.

Defect of Protective Grounding

Do not operate the instrument when protective grounding might be defective.

Do not Operate in an Explosive Atmosphere

Do not operate the instrument in the presence of flammable liquids or vapors. Operation of any electrical instrument in such an environment constitutes a safety hazard.

Do not Remove any Covers

There are some areas with high voltage. Do not remove the cover if the power supply is connected. The cover should be removed by qualified personnel only.

External Connection

To ground securely, connect the protective grounding before connecting to measurement or control unit.

Usage of This Manual

This manual consists of the following chapters, Chapter 1 to Chapter 9, and an Index. Before using the counter for the first time, operators should read the chapters sequentially from the beginning. If you encounter unfamiliar terms, consult the index for further reference.

Chapter	Title	Contents
1	Functions Performed with TC100 Series Counters	Features, functions, and component names of the TC100 series are described.
2	Notice Prior to Use	Items to be noted prior to operation, such as checking of contents upon delivery, general notes on usage, installation, connection of the power cord, and input connections, are described.
3	Setting Measurement Conditions	Procedures for setting the measurement conditions, such as input coupling, attenuator, and filter, are described.
4	Carrying Out Measurements	The usage of each measurement function is described.
5	Other Functions	Procedures for the functions that initialize, store and recall measurement information, the hold-off function, common input function, scaling, display digit masking, etc. are described.
6	Using the Communication Function (GP-IB)	Operation for performing remote control or data output using the GP-IB interface is described.
7	Troubleshooting, Maintenance, Calibration, and Adjustment	Probable causes of failures and their countermeasures, the implications from error codes and their countermeasures, self-diagnosis, calibration, and adjustment procedures are described.
8	Performance Testing	Methods to test whether or not the performance of the TC100 series of counters meets the specifications are described.
9	Specifications	Specifications for the TC100 series counter unit are described.
	Index	Detailed listing of topics in alphabetical order

Symbols Used in This Manual

- **Displays**

The alphanumeric in sentences are what are actually displayed on the screen.

- **Special instructions**

Special instructions in this manual are differentiated by several marks (shown below) according to their nature.



This symbol is found on an instrument in the TC100 Series whenever special attention is needed for protecting the operator and the equipment. The necessary information is found in the User's Manual.



This mark is found in front of a special instruction given to prevent hazards to the operators life or body.



This mark is found in front of a special instruction given to prevent damage to an instrument in the TC100 Series.

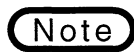

This mark is followed by important information about the way a product in the TC100 Series should be handled.

- **Symbols used in explanatory pages**

The following marks are used to differentiate information in explanatory descriptions in Chapters 4 to 7.

Before Starting

This mark is followed by necessary settings for a specific operation or any restrictions about that operation.

Operation Procedure

Perform operations by following them in the numbered order. Because these explanations are written with the premise that they are being done for the first time, there are instances where all operations concerning changing the setting contents are unnecessary.

CONTENTS

Introduction	1
Safety Precautions	2
Usage of This Manual	4
Chapter 1 FUNCTIONS PERFORMED WITH TC100 SERIES COUNTERS	
1.1 Operating Principles of TC100 Series Counters	1-2
1.2 Functions Available	1-4
1.3 Names of the Components on Each Panel and Their Functions	1-6
Chapter 2 NOTICE PRIOR TO USE	
2.1 Checking Package Contents	2-2
2.2 General Notes on Usage	2-4
2.3 Installation	2-6
⚠ 2.4 Connection of Power Cord	2-10
⚠ 2.5 Turning Power On/Off	2-12
⚠ 2.6 Input Connection	2-14
Chapter 3 SETTING MEASUREMENT CONDITIONS	
3.1 Setting Input Conditions	3-2
3.1.1 Selecting Input Coupling	3-3
3.1.2 Selecting Attenuator	3-4
3.1.3 Setting Filter	3-5
3.1.4 Setting Trigger Level	3-6
3.2 Setting Gate Time/Multiplier	3-8
Chapter 4 CARRYING OUT MEASUREMENTS	
4.1 Frequency Measurement	4-2
4.2 Period Measurement	4-4
4.3 Pulse Width Measurement	4-5
4.4 Time Interval Measurement	4-6
4.5 Duty Ratio Measurement	4-7
4.6 Frequency Ratio Measurement	4-8
4.7 Peak-voltage Measurement	4-9
4.8 Totalized-count Measurement	4-10
4.9 Measurement of Number of Revolutions (for TC110 counter only)	4-12
4.10 Changing Display Readout (Measured Value, Trigger Level, and Hold-off Time)	4-13
4.11 Holding Display	4-14
4.12 Measurement Accuracy	4-15
Chapter 5 OTHER FUNCTIONS	
5.1 Storing/Recalling Settings	5-2
5.2 Using Hold-off Function	5-4
5.3 Initializing Settings	5-6
5.4 Making Input Common to Channels A and B	5-7
⚠ 5.5 Using External Reference Signal Input and Reference Signal Output	5-8
5.6 Utilities	5-10
5.6.1 Scaling	5-12
5.6.2 Using Displayed-digit Masking Function	5-13
5.6.3 Checking Reference Signal/Software Version	5-14
5.6.4 Digital/Analog Conversion Output (optional function)	5-15
5.6.5 Using the Handler Interface (optional function)	5-17

Chapter 6 USING THE COMMUNICATION FUNCTION (GP-IB)		
6.1 Outline of Communication Function	6-2	
6.2 Communication Function Specifications	6-3	
6.3 Response to Interface Messages and Operation in Remote/Local Transfer	6-4	
6.4 Status Byte Format	6-5	
6.5 Address/Address Mode Setting	6-6	
6.6 Measured Data Output	6-7	
6.7 Notice Prior to Programming	6-8	
6.8 Commands	6-9	
6.9 Sample Program for NEC PC-9801 Series Computer	6-22	
6.10 Sample Program for IBM PC/AT Computer	6-26	
Chapter 7 TROUBLESHOOTING, MAINTENANCE, CALIBRATION, AND ADJUSTMENT		
7.1 Experiencing Failure? First Make an Examination Yourself	7-2	
7.2 Implications of Error Codes and Their Countermeasures	7-3	
7.3 Executing Self-diagnosis	7-4	
7.4 Calibration and Adjustment	7-6	
7.5 Office to Contact if a Failure Occurs	7-8	
Chapter 8 PERFORMANCE TESTING		
8.1 Preparing for Performance Testing	8-2	
8.2 Doing the Performance Test	8-3	
8.2.1 Testing Input Sensitivity	8-3	
8.2.2 Test for Frequency Measurement Accuracy	8-4	
8.2.3 Test for Time Interval Measurement Accuracy	8-5	
Chapter 9 SPECIFICATIONS		
9.1 Specifications for Each Measurement Function	9-2	
9.2 Input Block Specifications	9-5	
9.3 Reference Time Specifications	9-6	
9.4 Optional Specifications	9-6	
9.5 General Specifications	9-8	
9.6 External Dimensions	9-9	
INDEX		
Alphabetical Index	Index-2	

1

2

3

4

5

6

7

8

9

Index

Chapter 1

FUNCTIONS PERFORMED WITH TC100 SERIES COUNTERS

1.1	Operating Principles of TC100 Series Counters	1-2
1.2	Functions Available	1-4
1.3	Names of the Components on Each Panel and Their Functions	1-6

1.1 Operating Principles of TC100 Series Counters

General

The TC110/120 Universal Counters adopt reciprocal frequency counting and can measure even low frequency signals with high resolution. They realize a time resolution of 10 ns because of their use of multi-phase clock systems.

Measurement Principle

The principle described here is for the method realizing a time resolution of 10 ns. The following figure shows a timing chart for internal clocks and an input signal:

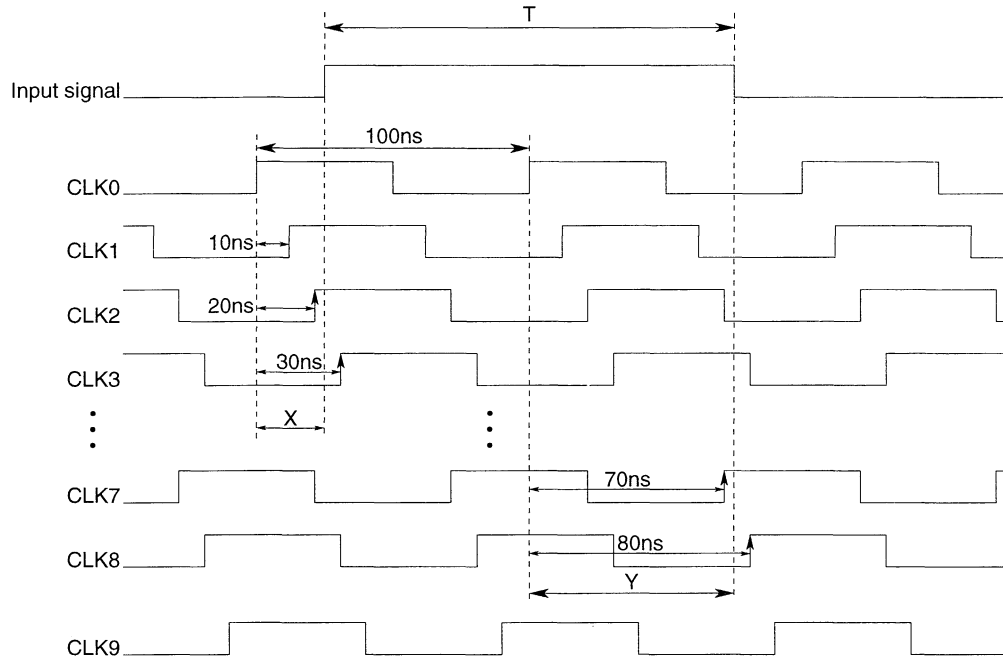

CLK0 to CLK9 above are ten-phase clocks whose phases shift by 10 ns each. The input signal is converted to a pulse in the counter as shown. Resolution of the reference clock period or better is realized by measuring the timing of the rising and falling edges of this pulse in the 10-phase clocks.

Since the rising edge of the input pulse occurs between CLK2's and CLK3's pulses, $X=30$ ns, determined by considering the phase shift from the reference clock (CLK0).

Similarly, since the falling edge of the input pulse occurs between CLK7's and CLK8's pulses, $Y=80$ ns.

In the example above, the duration T of input signal is calculated from the fact that one period of the reference clock is counted during the measuring time and using the phase values for rise and fall as shown below.

$$T=100 \text{ ns}-30 \text{ ns}+80 \text{ ns}=150 \text{ ns}$$

As shown above, a resolution of 10 ns can be realized by employing ten-phase clocks.

Block Diagram

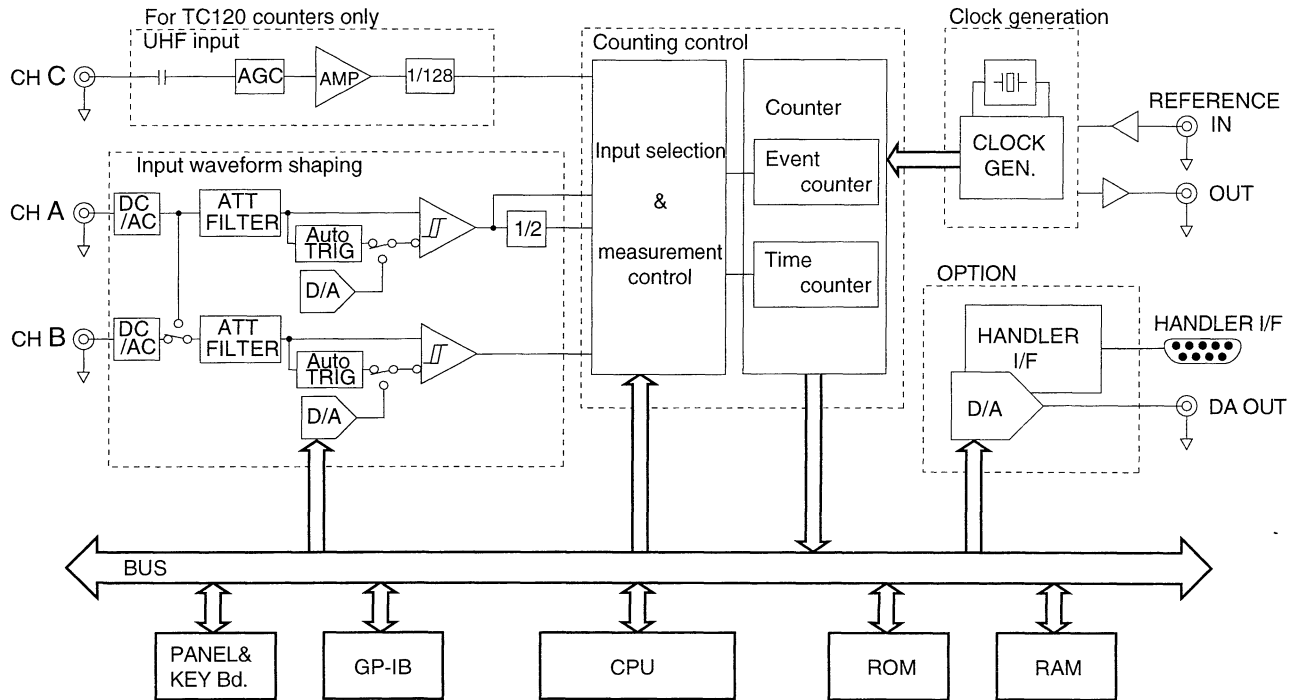

Signals input from channels A and B are digitized in the input waveform-shaping circuit and transmitted to the counting control circuit. In the counting control circuit, pulse trains are generated depending on the selected function and channels and are sent to the second-stage counters. In the counter block, the time is measured using the ten-phase clocks generated by the clock generating circuit (see the preceding page). The measured value is computed from the time-measured data and then displayed.

1.2 Functions Available

- **Measurement Functions**

- The relationship between measurable items and input channels is as shown below.

Input Channel \ Measurable Item	A	B	C (TC120)
Frequency	1Hz~120MHz	1mHz~60MHz	100MHz~2GHz
Period	—	20ns~999.999999s	—
Time interval	A→B 60ns~999.999999s		—
Pulse width	—	20ns~999.999999s	—
Duty ratio	—	0.00000001~ 0.99999999	—
Frequency ratio	A/B 1mHz~60MHz		—
Totalized counting	0~999999999	—	—
Peak voltage	±5V(ATT=×1)	±5V(ATT=×1)	—
Number of revolutions (TC110)	—	60mrpm~120Mrpm	—

- **Input functions common to channels A and B**

- A channel A input is internally converted to an input common to channels A and B. In this case, the input connector of channel B is isolated from the internal circuit.
- The period, pulse width, time interval, duty ratio, frequency ratio, and number of revolutions (TC110) for the input of channel A can then be measured.

- **Hold-off function**

The input signal is ignored during a period specified in the range of 100 μs to 100 ms after the first edge of the input signal is detected.

- **Scaling function**

- Conversion to any physical quantity is enabled by setting the values of a and b in the expression (aX + b) where X is the measured value.
- The expression can be set in the two programs, PROG1 and PROG2, and these settings are stored in the internal non-volatile memory.

- **Display digit-masking function**

Any number of least significant digits of the displayed nine digits can be masked. This eliminates the display of unnecessary digits.

- **Display-holding function**

This function holds and restarts measurement and display.

- **Auto-trigger function**

This function detects the middle of the input signal amplitude and applies the trigger by taking that value as the trigger level. It can also apply a trigger at any level.

- **Function to store/recall set information**

Set information can be stored in or recalled from the internal non-volatile memory.

- **Function to sample measured data at high speed**

Use of communication function allows measured data to be collectively stored (1024 words) at high speed in the internal memory. Stored data can be read collectively after measurement. Analysis of the variation in measured values with time is also possible because time data can be added when data are read.

- **D/A output function (optional)**

Measured values are converted to voltages of 0 to 10 V to output analog voltages.

- **Handler interface function (optional)**

This is a comparator function which sorts all measured values except peak voltages into five ranks.

1.3 Names of the Components on Each Panel and Their Functions

• Display Panel

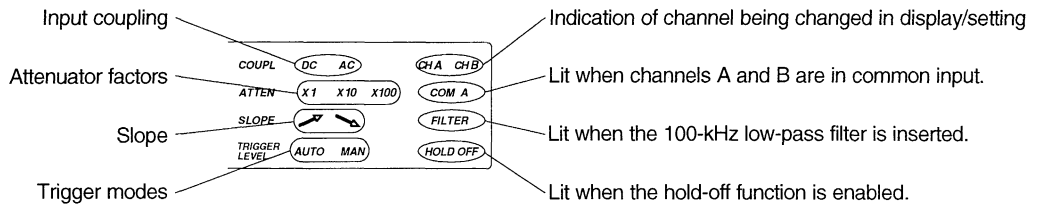
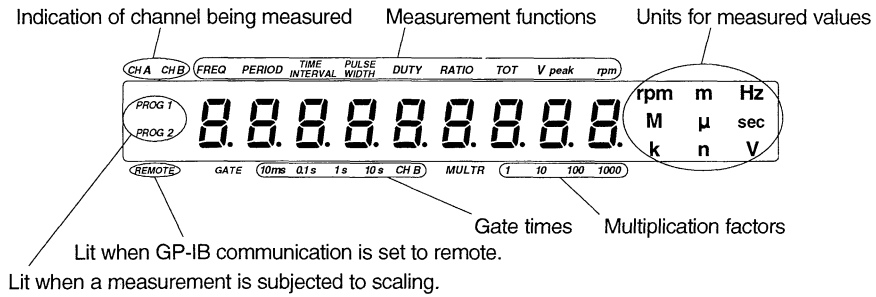

• LEDs for shift key and display-hold key

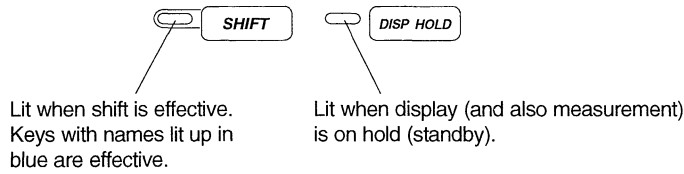

• LEDs for numeral setting key

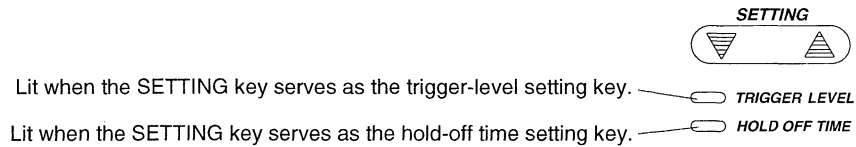

• LEDs for input terminals

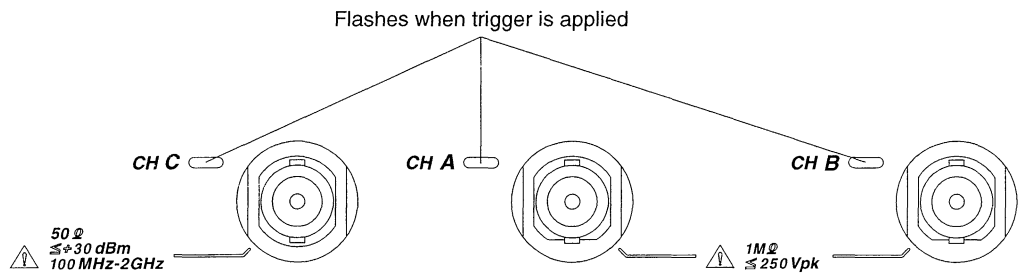

Front Panel

- **Front Panel of the TC120 Counter (with channel C input)**

• The numbers to the right of the panel key names indicate the sections or subsections in which the keys' functions are described in detail. Also, the keys with the names in the shaded areas are effective only while the **SHIFT** key is pressed.

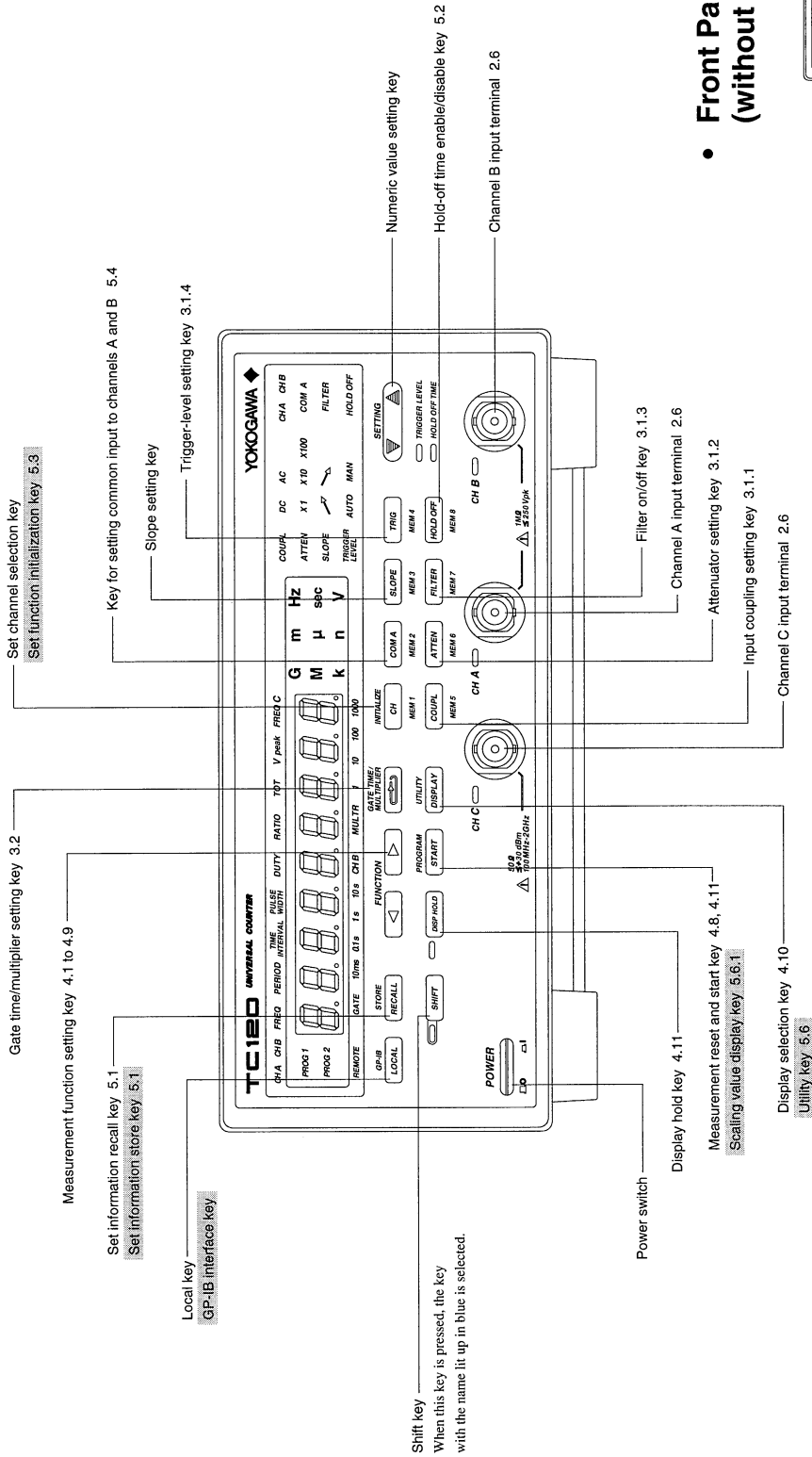

- **Front Panel of the TC110 Counter (without channel C input)**

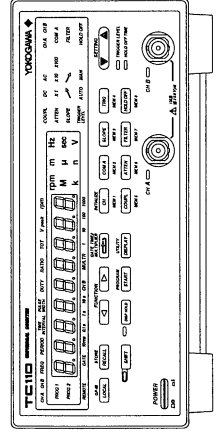

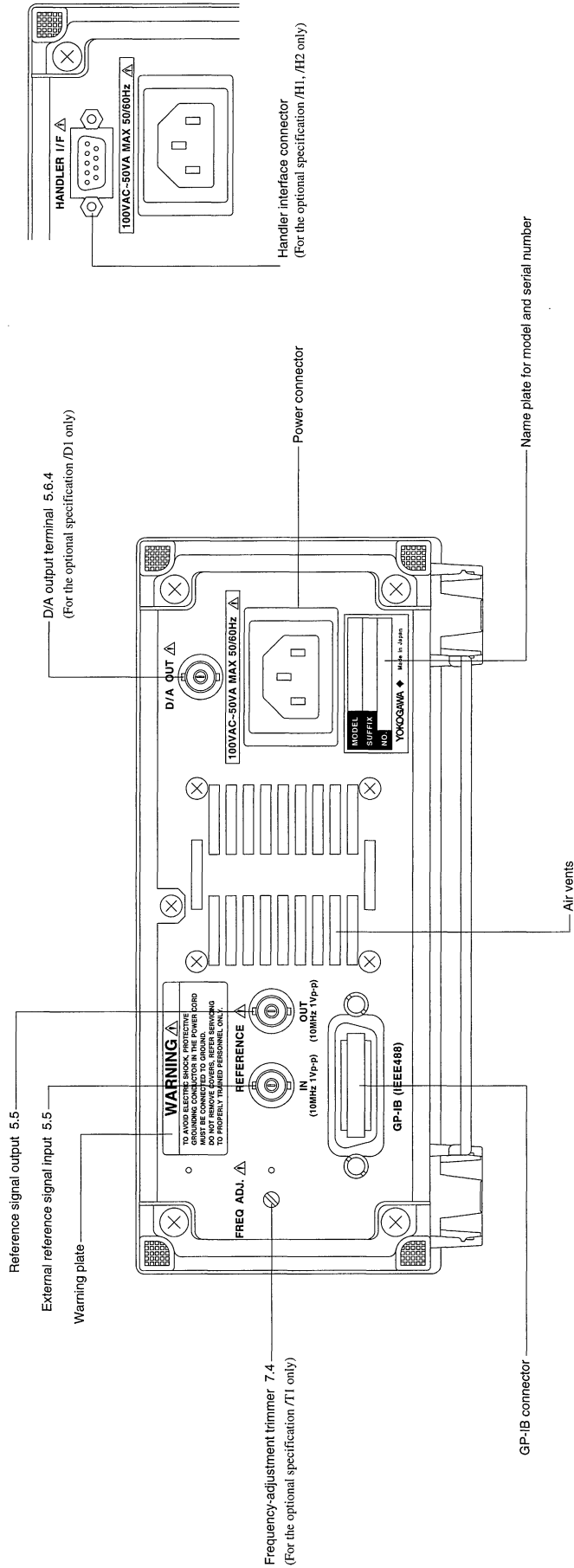

Rear Panel
 • Rear Panel of TC110/TC120 Counters



Chapter 2

NOTICE PRIOR TO USE

2.1	Checking Package Contents	2-2
2.2	General Notes on Usage	2-4
2.3	Installation	2-6
	2.4 Connection of Power Cord	2-10
	2.5 Turning Power On/Off	2-12
	2.6 Input Connection	2-14

2.1 Checking Package Contents

When unpacking the instrument, check the contents received before installing it. If any items are missing or there is any damage to the outside, contact your dealer. At that time, let the dealer know the model of your TC100 series counter, and the serial number.

TC100 series counter

Check the model and suffix codes printed on the name plate on the rear panel for the model and serial numbers to confirm that the TC100 series counter is the product specified in the purchase order.

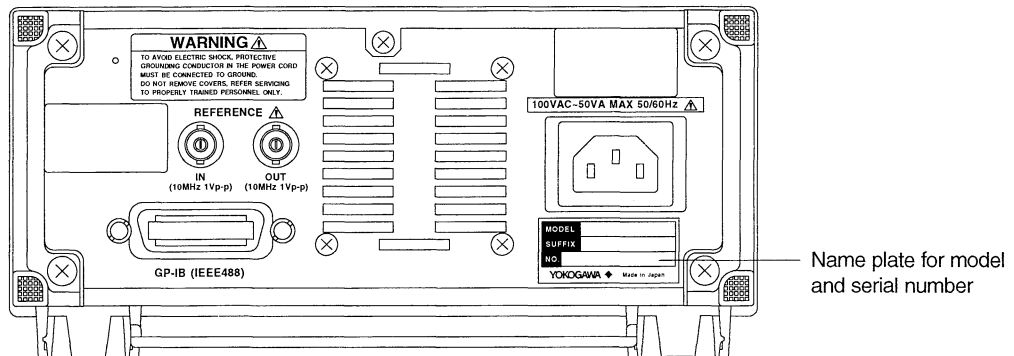

• MODEL

Model	Basic Specification
704111	TC110, Without channel C input
704112	TC120, With channel C input

• SUFFIX (Specification codes)

Suffix Code	Part Number	Description
Supply voltage	-1	100 V AC 50 or 60 Hz
	-4	120 V AC 50 or 60 Hz
	-7	230 V AC 50 or 60 Hz
Power supply code	-D	A1006WD UL- and CSA-approved standards: maximum rated voltage 125 V, maximum rated current 7 A
	-F	A1009WD VDE-approved standards: maximum rated voltage 250 V, maximum rated current 10 A
	-R	A1024WD SAA-approved standards: maximum rated voltage 240 V, maximum rated current 10 A
	-J	A1023WD BS-approved standards: maximum rated voltage 250 V, maximum rated current 5 A
Optional features	/T1	Highly stable timebase
	/D1	D/A output
	/H1	Handler interface (isolated model)
	/H2	Handler interface (non-isolated model)

• NO. (Serial number)

When contacting the dealer, let him know this number.

Accessories and inspection

Each TC100 series counter has the following accessories. Check that all the accessories are accounted for, and that the counter has sustained no damage.

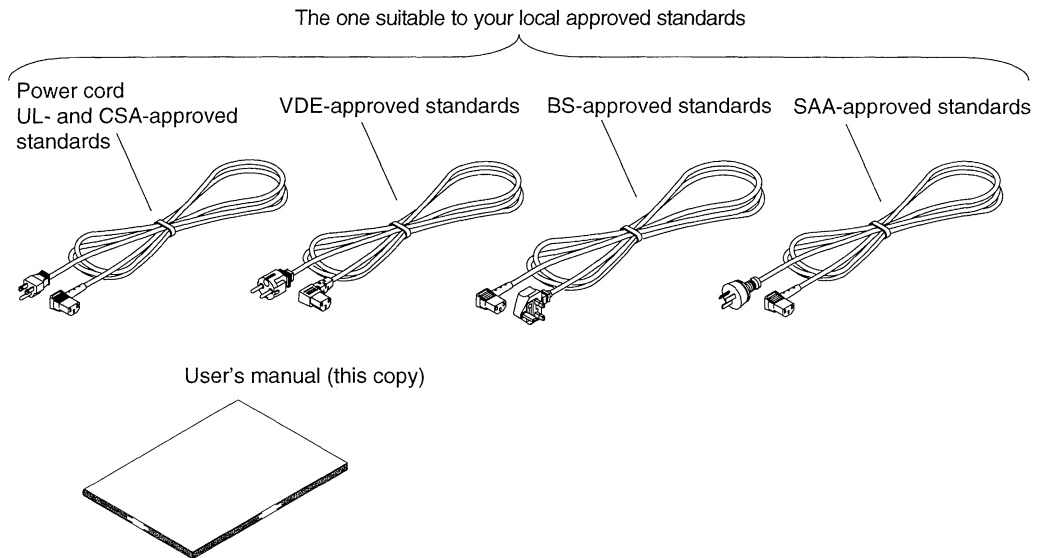

Optional accessories (sold separately)

The optional accessories are shown below. When you receive your order, check that all those optional accessories you requested are accounted for, and that they have sustained no damage. For inquiries or orders, contact your dealer.

Name	Model	Specification
Cable with BNC connector	366924	BNC-BNC, 1 m
Cable with BNC connector	366925	BNC-BNC, 2 m
Cable with BNC connector and alligator clips	366926	1 m cable with BNC connector and alligator clips
Conversion adapter	366921	Cable with BNC connector (plug) and banana terminal (jack)
Connection adaptor	366923	T-shaped connecting adapter (for BNC connector)
50 Ω terminator	700976	Through terminator
Rack-mounting kit	751501	EIA standards; single mounting
Rack-mounting kit	751502	EIA standards; multiple mounting of racks adjacent to each other
Rack-mounting kit	751503	JIS standards; single mounting
Rack-mounting kit	751504	JIS standards; multiple mounting of racks adjacent to each other

Note

- It is recommended that you retain the packing carton. It may be useful if you need to transport this product.

2.2 General Notes on Usage

General Handling Precautions

Observe the following general precautions about the handling of the Synthesized Function Generator in the TC100 Series:

- Do not place anything on the equipment.
 - Placing other equipment or objects containing liquids on it may cause malfunction.
- Observe the following precautions when moving the instrument.
 - Disconnect power cords and cables.
 - Always carry it by the handle as shown.

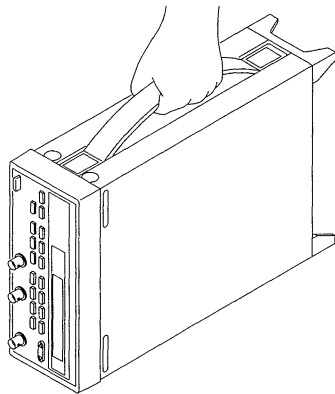

- Do not close the vent hole in the case to prevent temperature rise in the instrument.
- Keep input and output terminals away from electrically charged articles as they may damage the internal circuits.
- Do not put volatile chemicals on the case or the operation panel or keep rubber or vinyl products in contact with them over an extended period of time. They may cause deterioration of material.
- Unplug the power cord when you do not plan to use the instrument over an extended period of time.

Precautions for operation safety

- Do not remove the TC100 series counter from its case.
- Some portions of the counter inside the case carry high voltage and any contact with them is dangerous.
- For checks or adjustments of the circuits or controls inside the unit, contact your nearest Sales/Service center. Addresses may be found on the back cover of this manual. However, units with a highly stable timebase can be adjusted with the frequency-adjustment trimmer. (See page 7-7).
- If any abnormal symptoms appear such as smoke or odors emanating from the TC100 series counter, immediately turn the power switch off and pull the power cord plug out from the outlet. Also, disconnect all connections to the I/O terminals.
- In the case of a malfunction, contact your nearest Sales/Service center. Addresses may be found on the back cover of this manual.
- Avoid setting anything on the power cord or allowing it to touch any source of heating.
- If the cord is damaged, contact your dealer.
- When disconnecting the power cord from an outlet, do not pull on the cord; pull the plug by holding it firmly.

Storage

When storing the TC100 series counter, avoid the following:

- Highly humidity of 80% R.H. or greater
- Exposure to direct sunlight
- High temperatures of 40°C or greater, and low temperatures of -20°C or less.
- Close proximity to a high-temperature heat source
- Severe mechanical vibration
- Presence of corrosive or flammable gases
- Presence of a lot of dust, trash, salt or iron powder in the atmosphere
- An area where water, oil or chemicals are splashed about.

2.3 Installation

Precaution

WARNING

- To prevent fire hazards, never stand the instrument on its back (see shown). A cooling fan vent is located at the back. If it is closed, it may cause fire after malfunction. When it must be installed on its back for any reason, put a metal plate (or flame-retardant barrier of UL94-1 or higher grade) under it. However, the instrument may be damaged when it falls.

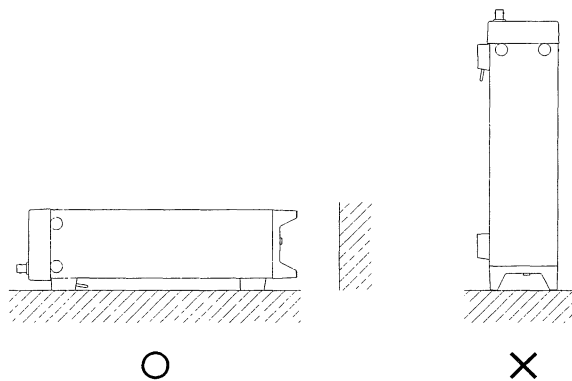

Location

The instrument must be installed in a place that meets the following conditions.

- **Ambient temperature and humidity**

Ambient temperature : 5 to 40°C or $23 \pm 2^\circ\text{C}$ when higher precision is necessary

Ambient humidity : 20 to 80%RH and without moisture condensation

Note

Moisture may condense when the instrument is moved from a cold and dry place to a warm and humid place, or as the result of quick change in the room temperature. When condensation is expectable, leave the instrument in the new environment for at least one hour before usage.

- **Well-ventilated place**

A vent hole is located under the instrument. Do not close the hole under any circumstances. In addition, a cooling fan vent is located in the back of the case. Leave adequate space in back of the instrument as shown, and make certain the vent holes are never closed to prevent temperature rise inside of the instrument.

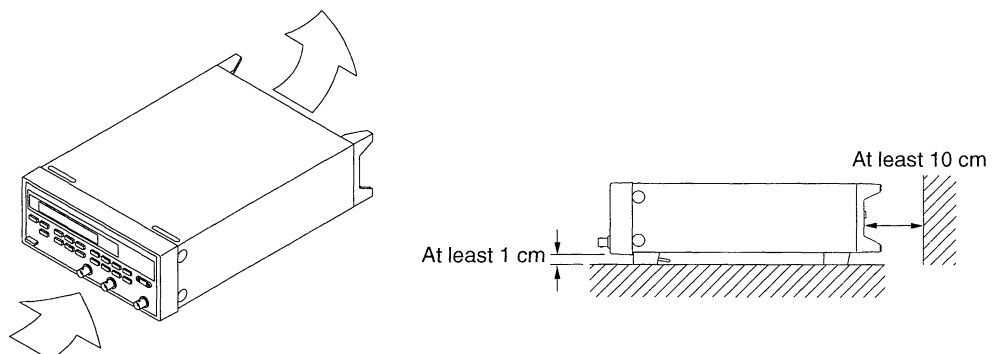

Avoid installing this unit in the following locations:

- With exposure to direct sunlight or near heat sources
 - The case and internal circuits will be adversely affected if the unit is exposed to direct sunlight or installed near a heat source. Choose a location where temperature changes are as slight as possible.
- Areas of excessive soot, steam, dust, corrosive gases, etc.
 - Soot, steam, dust, corrosive gases, etc. will cause malfunctions in or damage to the unit.
- Near electromagnetic generating sources
 - If the TC100 series counter is used near a strong electromagnetic field generating source, the electromagnetic field will have an adverse effect on the internal circuits of the unit.
- Near high-voltage equipment or power lines
 - Do not install the unit near a noise source, such as high-voltage equipment and/or power line in order to improve its noise immunity.
- Areas of mechanical vibration
 - Installing this unit where mechanical vibration is severe will not only adversely affect the components of the unit but may also prevent proper measurement.
- Unstable surfaces
 - Using the unit on an unstable surface brings on the possibility of it falling.

Angle of installation and space

• Flat surface

Place the unit on a flat surface or at an angle with the stand as shown in the figure below. When using the stand, set against the bottom of the unit, pull the leg forward until it is at a right angle to the bottom, and it locks in place. When not using the stand, push the left and right legs back up to return them to their previous position.

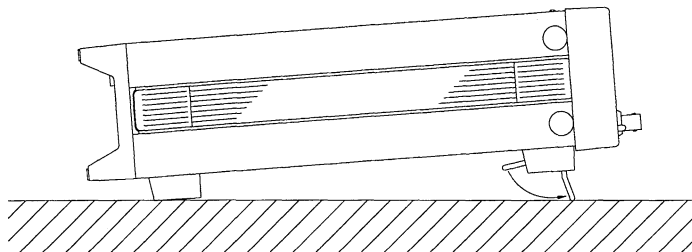

• Rack mounting

When mounting the TC100 series counter in a rack, use a rack-mounting kit (available separately).

- Rack-mounting kits, available as optional accessories

Name	Model	Standards	Specification
Rack-mounting kit	751501	EIA	Single-mounting rack
Rack-mounting kit	751502	EIA	Multiple-mounting rack
Rack-mounting kit	751503	JIS	Single-mounting rack
Rack-mounting kit	751504	JIS	Multiple-mounting rack

CAUTION

- The TC100 series counter has ventilation slots at the bottom of its cabinet. It also has air vents for the cooling fan in the back. When mounting the unit in a rack, there should be a clearance of more than 1 cm between the bottom of the unit and the surface and more than 10 cm behind the unit in order to prevent overheating.

• Mounting procedure

1. Remove the seal cover from the rack-mounting holes near the front panel on the left and right sides of the unit.
2. Attach the rack-mounting brackets as shown in the figure below.
3. Remove the four legs from the bottom of the unit.
4. Mount the unit in the rack.
 - When installing the unit, always support it from the bottom.
 - For rack-mounting dimensions, see page 9-9.

• EIA Rack (single Mount)

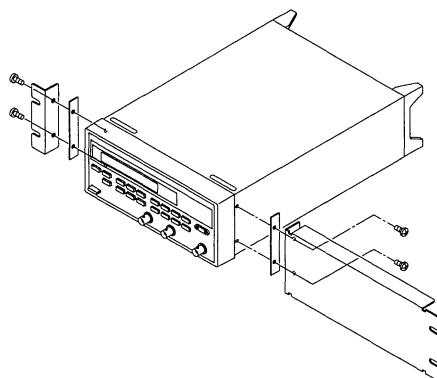

• EIA Rack (Double Mount)

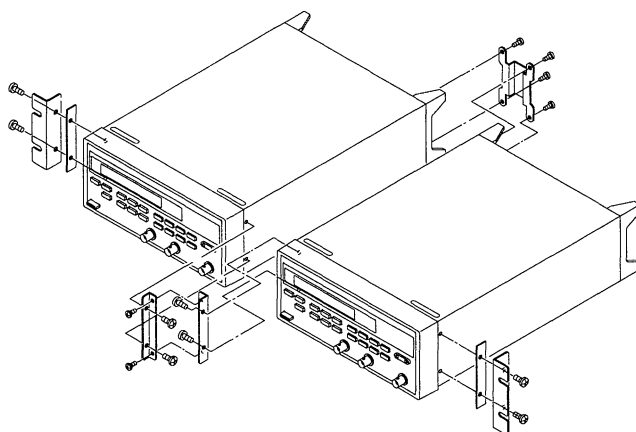

- JIS Rack (Single Mount)

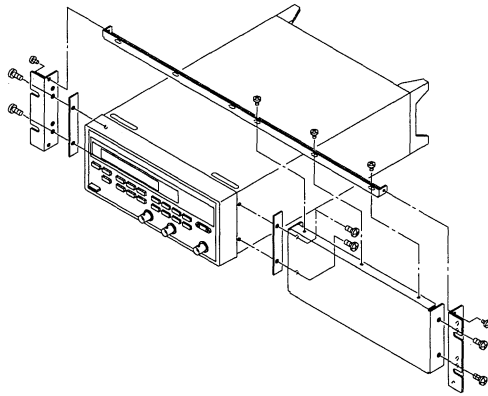

- JIS Rack (Double Mount)

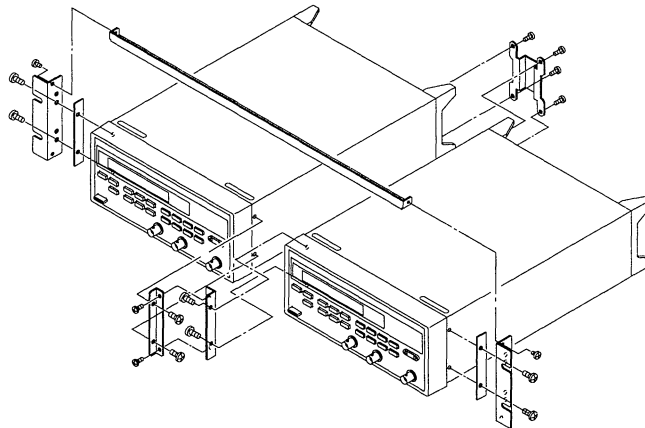

- Connect Double-Mount Racks as shown below.

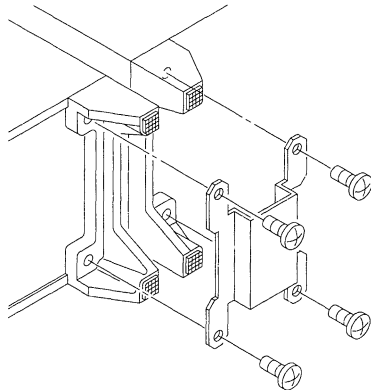

Rear Panel Side of 751502 or 751504

2.4 Connection of Power Cord

Before Connecting the Power Cord

Read the warning below before connecting the power cord. Negligence may cause electric shocks or damage to the instrument.



WARNING

- Make certain that the voltage supply complies with the rated supply voltage of the instrument before power connection.
- Make certain that the power switch on the instrument is turned off before connecting the power cord.
- Always use protective ground to prevent electric shock. Connect the TC100 series power cord to the 3-pin power outlet with grounding terminal.
- Do not use non-grounding extension cords or other measures that defect the protective grounding.

Procedure

1. Make sure that the power switch in the lower part of the front panel of the TC100 series counter is turned off.
2. Connect the power cord (accessory) to the power connector on the rear panel of the TC100 series counter.
3. Connect the other plug of the power cord to an outlet as described here. It must be connected to a 3-prong grounded outlet.

Specifications for Power Supply

	7041□□-1	7041□□-4	7041□□-7
Rated supply voltage	100 V AC	120 V AC	230 V AC
Supply voltage fluctuation tolerance	Rated supply voltage $\pm 10\%$	Rated supply voltage $\pm 10\%$	Rated supply voltage $\pm 10\%$
Rated power supply frequency	50 or 60 Hz	50 or 60 Hz	50 or 60 Hz
Power supply frequency fluctuation tolerance	48 to 63 Hz	48 to 63 Hz	48 to 63 Hz
Power consumption	Maximum 60 VA	Maximum 60 VA	Maximum 60 VA

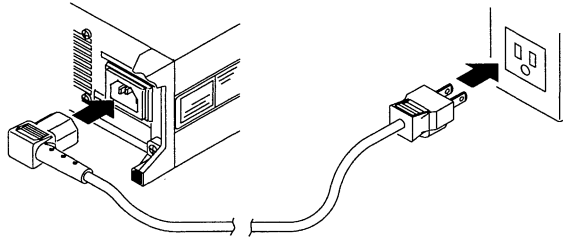

2.5 Turning Power On/Off

Check the Following Before Turning Power ON

- That the instrument is installed correctly as instructed in Section 2.3 Installation (page 2-6).
- That the power cord is connected correctly as instructed in Section 2.4 Connecting the Power Cord (page 2-10).

Location of the Power Switch

The power switch is located at the lower left corner of the front panel.

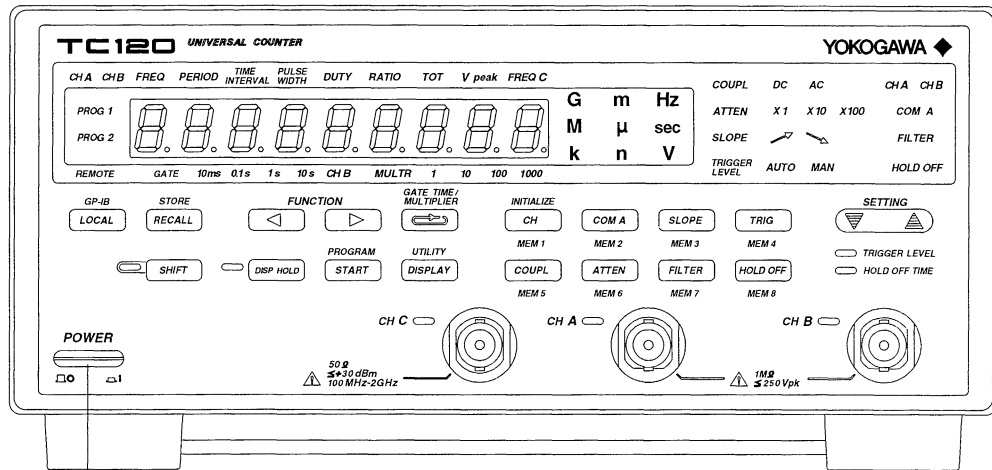

Power switch

Power ON/OFF Operation

The power switch is an alternating pushbutton. It goes "ON" and "OFF" alternately each time it is pushed in.

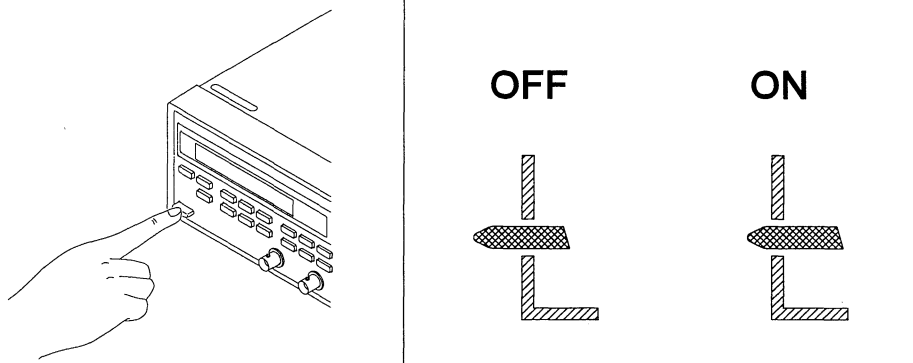

Note

The equipment requires a warm-up time of approximately 30 minutes before all specifications are available.

Operation and display when power is turned on

When the power switch is turned on, the test program starts up. Through this program, each memory slot is checked and so forth. If each check turns out normal, the opening messages are displayed as shown below and measurement can be started.

- After the test program is completed, if the following error codes are displayed, the TC100 series counter will not operate normally.
In this case, immediately turn the power switch off and contact your nearest Sales/Service center. Addresses may be found on the back cover of this manual.
When contacting Yokogawa, let the representative know the model and serial numbers marked on the name plate attached to the rear panel and the displayed error number.

501	502
-----	-----

Note

If an error other than the above has been displayed, confirm the contents of the error in Section 7.2, "Implications of Error Codes and Their Countermeasures" (page 7-3) and solve the problem.

• Opening message

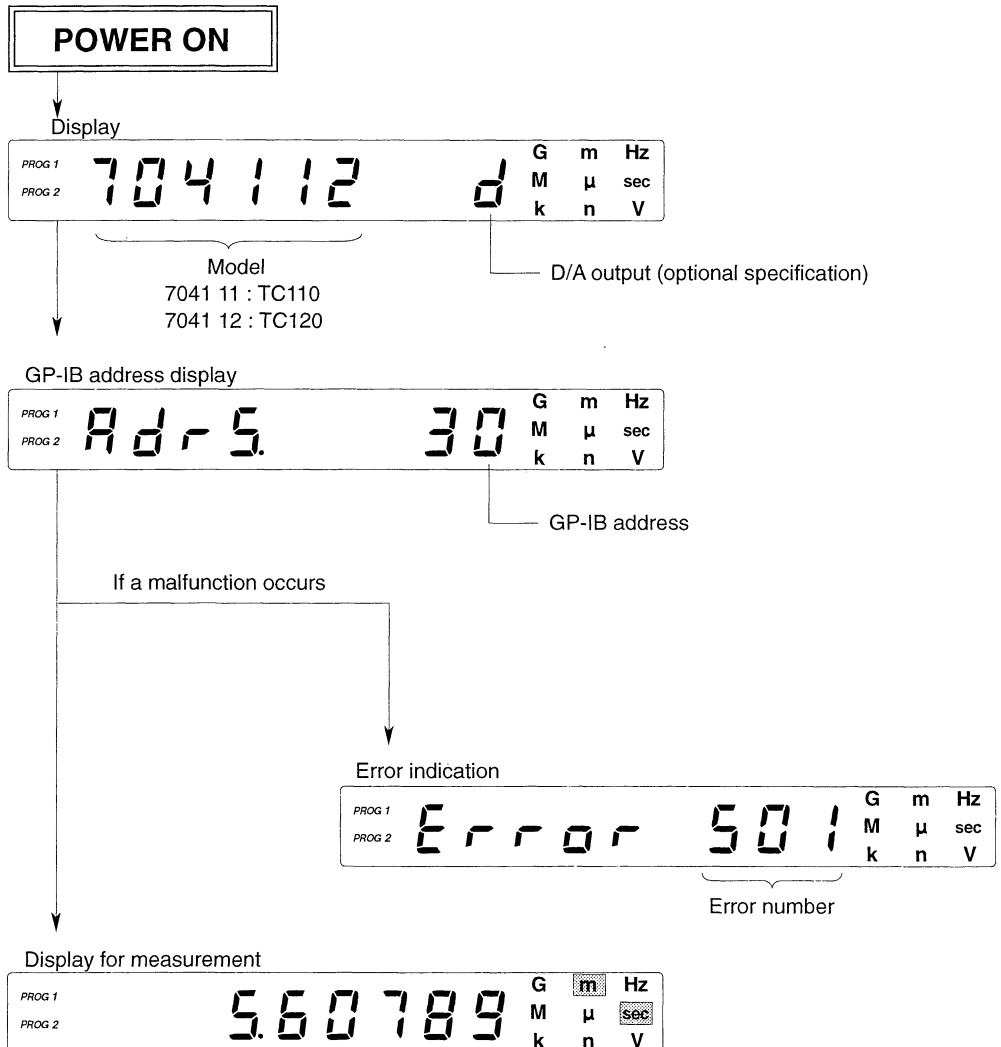

2.6 Input Connection

Notice when making connection



CAUTION

- Do not exceed the following maximum input voltage:

Maximum input voltage: 250 V (DC + AC peak)

- **Input impedance**

- When measuring high frequency, the input impedance gets excessively small because of the capacitance in parallel with the input. Therefore, if the input signal level is low, proper measurement might not be made.

In such a case, use an FET probe on the market whose input capacitance is small. When an FET probe is to be used, a 50Ω terminator (model number 700976) is necessary.

- For pulse and high-frequency signals whose rises are fast, mismatching between the signal source impedance (including the impedance of the cord) and the input impedance of this counter may cause reflections or waveforms to be distorted.

Also, resonance may be caused due to connection cables and the input capacitance of this counter.

In such cases, unless the impedances of the signal source and this counter match, proper measured results will not be obtained.

- **Error between channels**

When the time interval between channels A and B is to be measured in the order of ns, the difference in the length of the two cables in use will cause a measuring error.

In this case, equalize the length of those two cables or correct the result of the measurement by measuring the difference in the cable lengths in advance.

Chapter 3

SETTING MEASUREMENT CONDITIONS

3.1	Setting Input Conditions	3-2
3.1.1	Selecting Input Coupling	3-3
3.1.2	Selecting Attenuator	3-4
3.1.3	Setting Filter	3-5
3.1.4	Setting Trigger Level	3-6
3.2	Setting Gate Time/Multiplier	3-8

3.1 Setting Input Conditions

Input Conditions

- Set input conditions for each channel (A and B). This section describes in what cases setting of input conditions is necessary. For the procedures on setting each input condition, see the following:
 - Coupling → **Subsection 3.1.1, “Selecting Input Coupling” (page 3-3)**
 - Attenuator → **Subsection 3.1.2, “Selecting Attenuator” (page 3-4)**
 - Filter → **Subsection 3.1.3, “Setting Filter” (page 3-5)**
 - Trigger level → **Subsection 3.1.4, “Setting Trigger Level” (page 3-6)**
- Set input conditions are retained for each channel.
- **Channel A (1 Hz to 120 MHz)**
Set the input conditions for the following measurement functions:
 - Frequency • Time interval • Frequency ratio
 - Totalized counting • Peak voltage
- **Channel B (1 mHz to 60 MHz)**
Set the input conditions for the following measurements:
 - Frequency of channel A (if the gate time is set to CHB)
 - Frequency • Period • Time interval
 - Pulse width • Duty ratio • Frequency ratio
 - Peak voltage • Number of revolutions (TC110)
 - Totalized counting (if the gate time is set to CHB)
- **Channel C (100 MHz to 2 GHz, TC120)**
Only frequency can be measured. In addition, setting is not necessary because the input conditions are fixed as shown below.
 - Coupling AC
 - Attenuator × 1
 - Slope ↗
 - Trigger level 0 V
 - Filter OFF
 - Hold-off OFF

3.1.1 Selecting Input Coupling

Before Starting

- **Input coupling**

AC : Only the AC components of an input signal are taken. If there are DC components in an input signal or an offset voltage is not stable, select AC coupling. The lower limit of the input frequency is approximately 35 Hz.

DC : All AC and DC components of an input signal are taken.

Operation Procedure

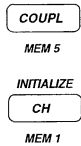

1. Select **DC** or **AC** using the **COUPL** key.

Every time the **COUPL** key is pressed, **DC** and **AC** are alternately selected.

2. If the desired measurement function is one of those below, select the channel in which coupling is to be set by pressing the **CH** key as necessary and carry out the operation described in **1**.

- Time interval
- Frequency ratio
- Frequency of channel A (if the gate time is set to channel B)
- Totalized counting (if the gate time is set to channel B)

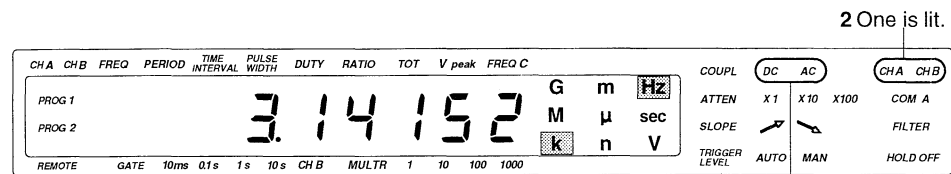

Note

Channel C is fixed to AC.

3.1.2 Selecting Attenuator

Before Starting

- **Selection of attenuator**
 - The trigger circuit of this counter is provided with a hysteresis and in the trigger level for noise immunity. However, if a measured signal includes noise exceeding the hysteresis band, a counting error may occur. In such a case, the noise is reduced and measurement becomes stable by selecting the attenuator to make the input signal level smaller.
 - The attenuator is also used for reducing the input voltage in a peak-voltage measurement.
 - When a signal of the level exceeding the operating voltage range is input, proper measurement might not be made. In such a case, it is necessary to reduce the input signal level by appropriately setting the attenuator.

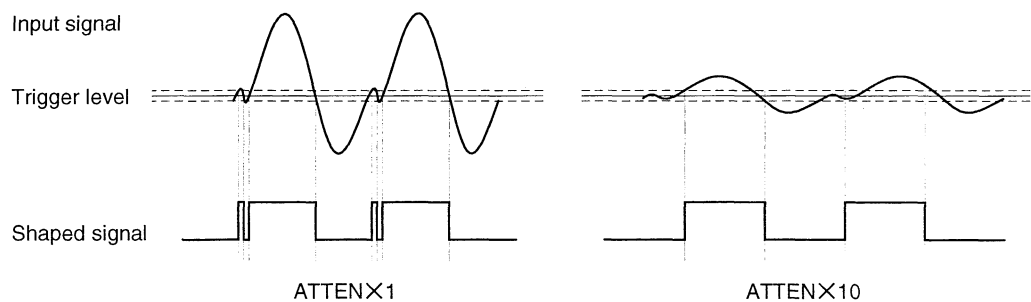

- **Operating voltage range**
-5 V to +5 V (for ATTEN $\times 1$)
- **Setting**
Can be selected from $\times 1$, $\times 10$, or $\times 100$.

Operation Procedure

ATTEN
MEM 6

INITIALIZE
CH
MEM 1

1. Select either $\times 1$, $\times 10$, or $\times 100$ by pressing the **ATTEN** key.
Every time the **ATTEN** key is pressed, selection follows the order of $\times 1 \rightarrow \times 10 \rightarrow \times 100 \rightarrow \times 1$.
2. If the desired measurement function is one of those below, select the channel in which the attenuator is to be set by pressing the **CH** key as necessary and carry out the operation described in 1.
 - Time interval
 - Frequency ratio
 - Frequency of channel A (if the gate time is set to channel B)
 - Totalized counting (if the gate time is set to channel B)

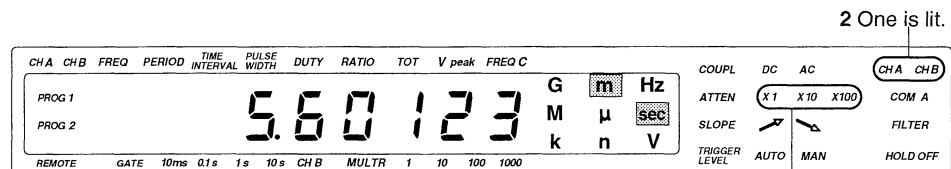

3.1.3 Setting Filter

Before Starting

- **Filter setting**
 - If a signal with impulse noise and H.F. random noise is directly measured, proper measurement might not be made. In such a case, noise components can be rejected by inserting a filter.
 - A 100 kHz low-pass filter can be set for both channels A and B respectively.
 - There is no filter setting for channel C (TC120).
 - The filter cannot be set for peak-voltage measurement.

Operation Procedure

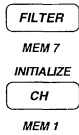

1. Pressing the **FILTER** key to light up the word **FILTER**.

2. If the desired measurement function is one of those below, select the channel in which the filter is to be set by pressing the **CH** key as necessary and carry out the operation described in 1.

- Time interval
- Frequency ratio
- Frequency of channel A (if the gate time is set to channel B)
- Totalized counting (if the gate time is set to channel B)

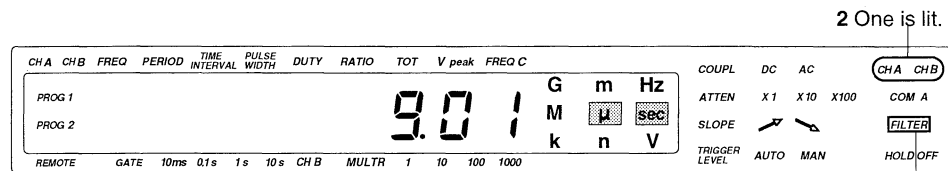

1 This key is lit.

3.1.4 Setting Trigger Level

Before Starting

Trigger Level and Slope

- The counter can detect the rising and falling edges of a signal, which are the references for measurement, based on the trigger level and slope as shown below.
- The input terminal LED flashes when triggering is generated.

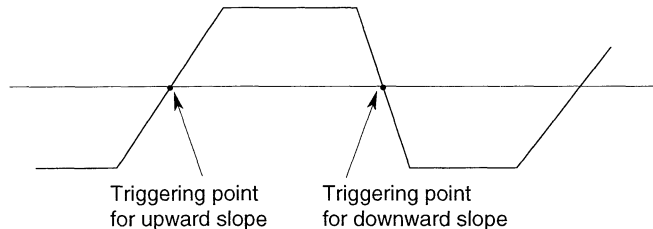

Auto-trigger Function

- Triggering is applied by detecting the middle of the input signal amplitude and making that value the triggering point.
- The auto-trigger level can be confirmed using the **DISPLAY** key when the trigger mode is changed from **[Auto]** to **[Manual]**.

Manual Trigger Function

The trigger level can be freely set in the following range:

- **Setting**

- The level can be set while carrying out measurement.
- The level can be set using the **SETTING** key when the **[TRIGGER LEVEL]** LED is lit.
- Each press of the **SETTING** key increases (or decreases) the level by one step. If the key is kept to be pressed, the level increases (or decreases) continuously. The degree of increase (or decrease) varies with the attenuator setting.

For ATTEN × 1	: -5.00 V to 5.00 V	; 20-mV steps
For ATTEN × 10	: -50.0 V to 50.0 V	; 200-mV steps
For ATTEN × 100	: -250 V to 250 V	; 2-V steps

Operation Procedure

Auto-trigger Function



Select [AUTO] by pressing the TRIG key.

Manual Trigger Function

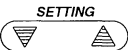

1. Select manual by pressing the TRIG key.
2. If the [TRIGGER LEVEL] LED is not lit (the [HOLD OFF TIME] LED is lit instead), press the TRIG key again.
3. Set the level using the SETTING key.
Pressing ▲ increases the numeric value and pressing ▼ decreases the value.

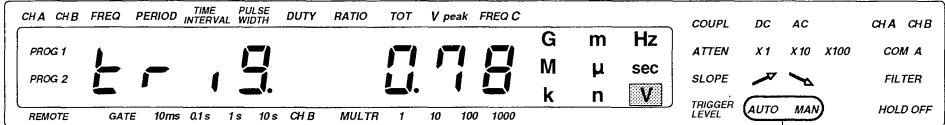

1 One is lit.

Note

- Pressing the DISPLAY key allows confirmation of the current trigger level. Also, when the TRIGGER LEVEL LED is lit, the trigger level can be changed using the SETTING key. However, when Auto-trigger is specified, [trig.AUto] is only indicated on the display.
- Depending on the input signal frequency, the rapidity at which the input terminal LED flashes, varies.

3.2 Setting Gate Time/Multiplier

Before Starting

Gate Time

- **Gate time and resolution**

In the measurement of frequency and the number of revolutions (TC110), the number of rises or falls of input signals is counted during the set gate time. The measurement is then determined from the number of counts and the gate time. Accordingly, the longer the gate time, the greater the number of counts; therefore, resolution is higher. However, as the gate time increases, the measuring time also increases but the display-update speed decreases. For the relationship between gate time and resolution, see **Section 4.12, “Measurement Accuracy” (page 4-15)**.

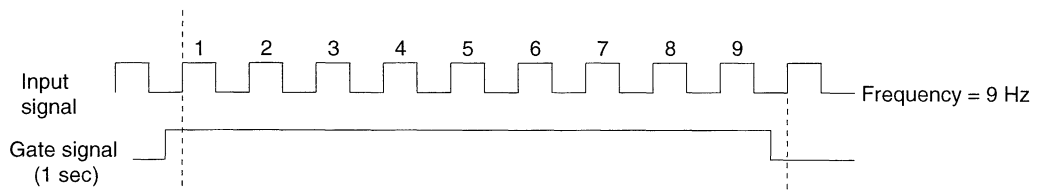

- **Measurement functions for which gate time can be set and the corresponding gate times**

Measurement function	Gate time
CHA FREQ	10 ms, 0.1 s, 1 s, 10 s, CHB*
FRQ C(TC120)	10 ms, 0.1 s, 1 s, 10 s
CHB FREQ	10 ms, 0.1 s, 1 s, 10 s
TOT	Channel B* or no setting
rpm(TC110)	10 ms, 0.1 s, 1 s, 10 s

* An input signal for channel B can be used for the gate time.

- **Using channel B as a gate signal**

- Measuring operation
 - When the slope of channel B input is ↗ (upward): The interval at which channel B input is high is the gate time.
 - When the slope of channel B input is ↘ (downward): The interval at which channel B input is low is the gate time.
- As the number of digits for each measurement displayed varies with the gate time, the number of digits can be controlled by the channel B input signal.
- Measurement timing can be controlled by the channel B input signal.

- **Gate time and number of digits displayed**

Gate time	10 ms	0.1 s	1 s	10 s
Number of digits	6	7	8	9

Multiplier

• **Multiplier and resolution**

In measurements other than those of frequency and the number of revolutions (TC110), the times for the continuous N periods set with the multiplier are measured and their average is taken as the measured value. Consequently, the larger the multiplier, the higher the resolution. However, increasing the multiplier results in a longer measurement time and a slower measurement display-update speed. For the relationship between the multiplier and resolution, see Section 4.12, “Measurement Accuracy” (page 4-15).

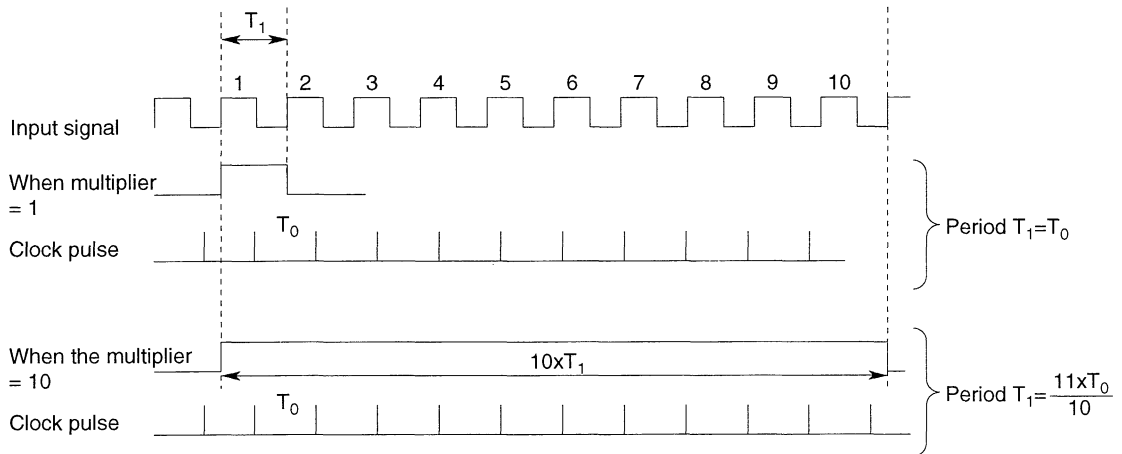

• **Measurement functions for which the multiplier can be set and the corresponding multipliers**

Measurement function	Multiplier
CHB PERIOD	1, 10, 100, 1000
CHA CHB TIMEINTERVAL	
CHB PULSE WIDTH	
CHB DUTY	
CHA CHB RATIO	

Operation Procedure



Press the **GATE TIME/MULTIPLIER** key.

- For gate time
Every time the key is pressed, selection follows the order of **10 ms** → **0.1 s** → **1 s** → **10 s** → **(CHB)** → **10 ms**.
- For multiplier
Every time the key is pressed, selection follows the order of **1** → **10** → **100** → **1000** → **1**.

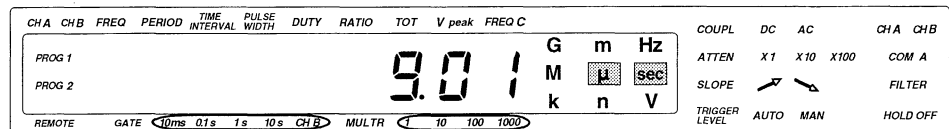

One of them is lit. One of them is lit.

Note

- When the hold-off function is set, the multiplier is fixed to 1.
- The set gate time/multiplier is stored for each measurement function.
- CHB can be selected in gate time selection, only when the measurement function is one of these two:
Frequency of channel A, Totalized counting

Chapter 4

CARRYING OUT MEASUREMENTS

4.1	Frequency Measurement	4-2
4.2	Period Measurement	4-4
4.3	Pulse Width Measurement	4-5
4.4	Time Interval Measurement.....	4-6
4.5	Duty Ratio Measurement.....	4-7
4.6	Frequency Ratio Measurement	4-8
4.7	Peak-voltage Measurement	4-9
4.8	Totalized-count Measurement	4-10
4.9	Measurement of Number of Revolutions (for TC110 counter only) ...	4-12
4.10	Changing Display Readout (Measurement, Trigger Level, and Hold-off Time)	4-13
4.11	Holding Display	4-14
4.12	Measurement Accuracy	4-15

4.1 Frequency Measurement

Before Operation

- **Measurable frequency ranges**

- Channel A (1/2 prescaler input) : 1 Hz to 120 MHz
- Channel B : 1 mHz to 60 MHz
- Channel C (1/128 prescaler input, TC120) : 100 MHz to 2 GHz

- **Resolution**

$$\frac{\pm 10 \text{ ns} \pm \sqrt{2} \times \text{Trigger error}}{\text{Gate time}} \times \text{Measuring frequency (Hz)}$$

- The resolution varies with the gate time setting, trigger error, ± 1 count error, etc. For details, see **Section 4.12, “Measurement Accuracy”** (page 4-15).

- **Guide to channel selection**

- The slope can be selected only for channel B. This is effective for signals in which a trigger error is likely to occur, such as a saw-tooth wave.
- For example, if a frequency to be measured varies between 100 MHz and 200 MHz, select channel C.
- Select the channel according to the frequency of the input signal.

- **Using channel B as a gate signal**

- If measurement is to be carried out in channel A, set CHB as the gate time.
- When the slope of channel B is ↗ (upward): The interval at which channel B input is high is the gate time.
- When the slope of channel B is ↘ (downward): The interval at which channel B input is low is the gate time.
- The input frequency range of channel A becomes 1 Hz to 60 MHz.
- CHB as a gate time cannot be set if channel B is selected as a measurement function.
- Channel C cannot use channel B as a gate signal.

- **Measurement timing**

- **Channel A**

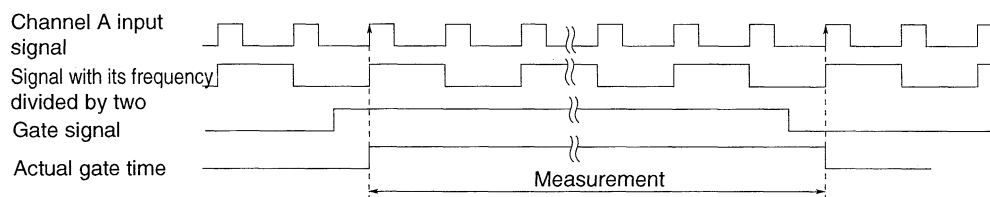

- **Channel B (slope is ↘ (downward))**

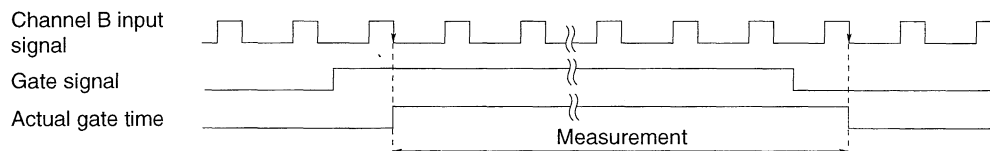

Operation Procedure

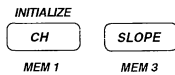
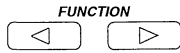

1. Measurement function setting

Select **CHA FREQ**, **CHB FREQ**, or **FREQC** by pressing the **FUNCTION** key.

Every time the **FUNCTION** key \triangleright is pressed, selection follows the order of [CHA][FREQ] → [CHB][FREQ] → [CHB][PERIOD] → [CHA][CHB][TIME INTERVAL] → [CHB][PULSE WIDTH] → [CHB][DUTY] → [CHA][CHB][RATIO] → [CHA][TOT] → [CHA][Vpeak] → [CHB][Vpeak] → [CHB][rpm] ([FREQC]). Pressing the **FUNCTION** key \triangleleft changes the selection in reverse order.

2. Gate time setting

Select the gate time from **10 ms**, **0.1 s**, **1 s**, or **10 s** (**CHB**) by pressing the **GATE TIME/MULTIPLIER** key.

For the gate time, see Section 3.2, “Setting Gate Time/Multiplier” (page 3-8).

3. If CHB is selected in the above setting for gate time:

- (1) Select **CHB** by pressing the **CH** key.
- (2) Select \nearrow or \searrow by pressing the **SLOPE** key.

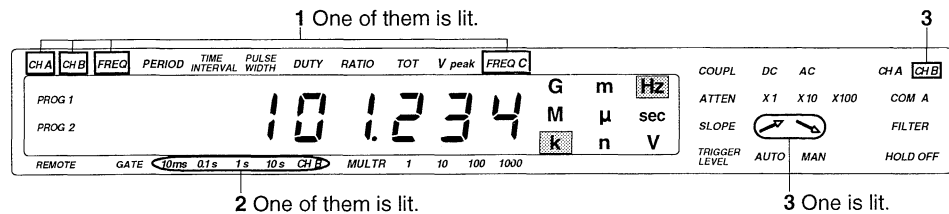

Note

Channel A and C are fixed to \nearrow (upward).

4.2 Period Measurement

Before Operation

- **Channel to be measured**
Channel B

- **Measuring range**
20 ns to 999.999999 s

- **Resolution**

$$\frac{\pm 10 \text{ ns} \pm \sqrt{2} \times \text{Trigger error}}{10^N} \text{ [s]} \quad \left(\begin{array}{l} 10^N \text{ denotes the multiplier,} \\ N = 0, 1, 2, \text{ or } 3 \end{array} \right)$$

- The resolution varies with the multiplier setting, trigger error, ± 1 count error, etc. For details, see **Section 4.12, “Measurement Accuracy” (page 4-15)**.

- **Measurement timing (if slope is ↗ (upward))**

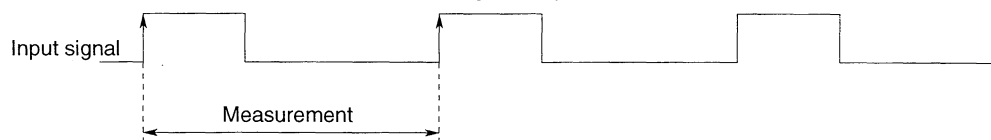

Operation Procedure

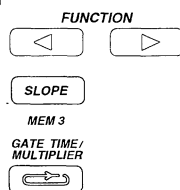

1. Setting measurement function

Select **CHB** and **PERIOD** by pressing the **FUNCTION** key.

2. Selection of slope

Select ↗ or ↘ by pressing the **SLOPE** key.

3. Setting multiplier

Select either **1**, **10**, **100** or **1000** by pressing the **GATE TIME/MULTIPLIER** key.

For multipliers, see **Section 3.2, “Gate Time/Multiplier” (page 3-8)**.

4.3 Pulse Width Measurement

Before Operation

- **Channel to be measured**
Channel B
- **Measuring range**
20 ns to 999.999999 s
- **Resolution**

$$\frac{\pm 10 \text{ ns} \pm \text{Trigger error for rise} \pm \text{Trigger error for fall}}{\sqrt{10^N}} \text{ [s]} \quad \left(10^N \text{ denotes the multiplier} \right)$$

N = 0, 1, 2, or 3.

- The resolution varies with the multiplier setting, trigger error, ± 1 count error, etc. For details, see **Section 4.12, “Measurement Accuracy”** (page 4-15).
- **Measurement timing (if slope is ↗ (upward))**

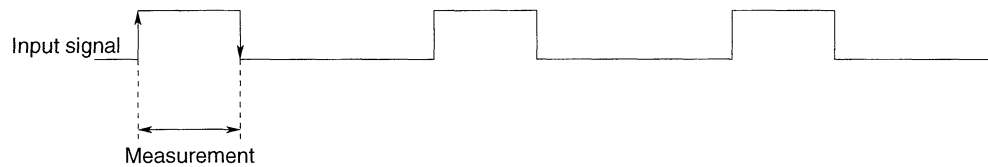

Operation Procedure

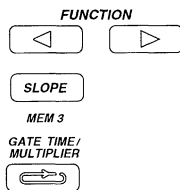

1. Setting measurement function

Select **CHB** and **PULSE WIDTH** by pressing the **FUNCTION** key.

2. Setting channel B slope

Select either ↗ or ↘ by pressing the **SLOPE** key.

3. Setting multiplier

Select either **1**, **10**, **100** or **1000** by pressing the **GATE TIME/MULTIPLIER** key.

For multipliers, see **Section 3.2, “Setting Gate Time/ Multiplier”** (page 3-8).

4.4 Time Interval Measurement

Before Operation

- **Channels to be measured**
Channels A and B
- **Measuring Procedure (channel A to channel B)**
Measure the time interval between the rise (fall) for channel A and the rise (fall) for channel B.
- **Input frequency range**
1 mHz to 50 MHz for both channels A and B
- **Measuring range**
60 ns to 999.999999 s
- **Resolution**

$$\frac{\pm 10 \text{ ns} \pm \text{Input trigger error for channel A} \pm \text{Input trigger error for channel B}}{\sqrt{10^N}} \text{ [s]} \quad \left(\begin{array}{l} 10^N \text{ denotes the multiplier.} \\ N = 0, 1, 2, \text{ or } 3. \end{array} \right)$$

- The resolution varies with the multiplier setting, trigger error, ± 1 count error, etc. For details, see Section 4.12, "Measurement Accuracy" (page 4-15).
- **Measurement timing (if slope A = ↗ and slope B = ↘)**

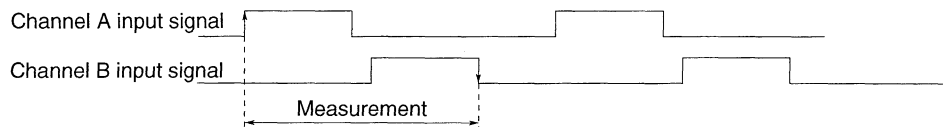

Operation Procedure

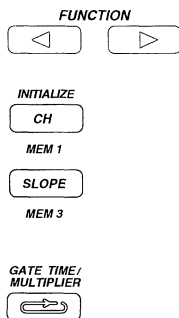

- 1. Setting measurement function**
Select **CHA**, **CHB**, and **TIME INTERVAL** by pressing the **FUNCTION** key.
- 2. Selection of the channel in which the slope is to be set**
Select **CHA** or **CHB** by pressing the **CH** key.
- 3. Setting slope**
Select ↗ or ↘ by pressing the **SLOPE** key.
- 4. Carry out steps 2 and 3 for both channels A and B.**
- 5. Setting multiplier**
Select either **1**, **10**, **100** or **1000** by pressing the **GATE TIME/MULTIPLIER** key.
For multipliers, see Section 3.2, "Setting Gate Time/ Multiplier" (page 3-8).

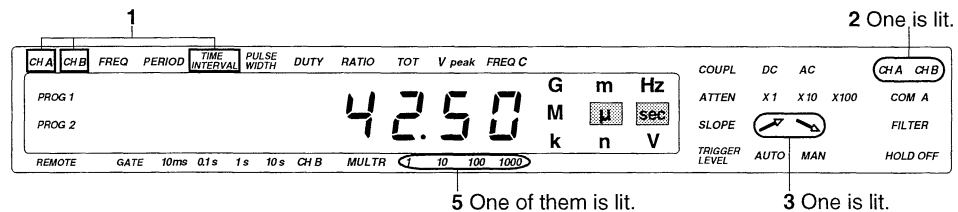

4.5 Duty Ratio Measurement

Before Operation

- **Channel to be measured**
Channel B
- **Measuring method**
Measure the pulse width and the period in channel B and calculate and display the pulse width/period.
- **Measuring range**
0.00000001 to 0.99999999
- **Resolution**

$$\pm \left(\frac{\text{Pulse width} + |\text{Pulse width resolution}^*|}{\text{Period} - |\text{Period resolution}^*|} - \text{Measured duty value} \right)$$

* For pulse width resolution and period resolution, see Section 9.1, "Specifications for Each Measurement Function" (page 9-2).

- The resolution varies with the multiplier setting, trigger error, ±1 count error, etc. For details, see Section 4.12, "Measurement Accuracy" (page 4-15).

- **Measurement timing (if slope is ↗)**

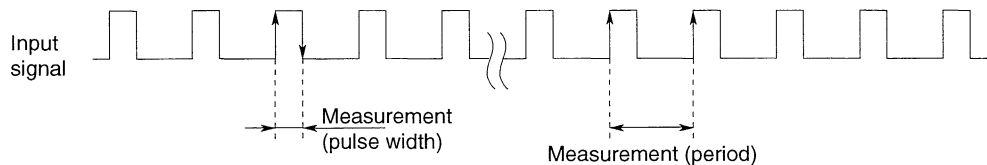

Operation Procedure

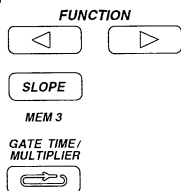

1. Setting measurement function

Select **CHB** and **DUTY** by pressing the **FUNCTION** key.

2. Setting channel B slope

Select ↗ or ↘ by pressing the **SLOPE** key.

3. Setting multiplier

Select either **1**, **10**, **100** or **1000** by pressing the **GATE TIME/MULTIPLIER** key.

For multipliers, see Section 3.2, "Setting Gate Time/ Multiplier" (page 3-8).

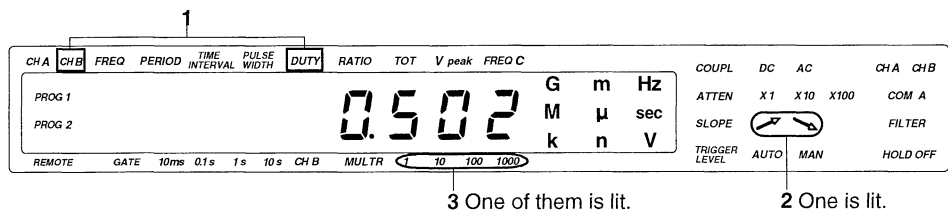

4.6 Frequency Ratio Measurement

Before Operation

- **Channels to be measured**
Channels A and B
- **Measuring method (channel A/channel B)**
 - The frequency ratio is determined by counting the number of pulses in channel A using the input signal for channel B as the gate. Accordingly, it is recommended that measurement be made with the frequency of channel A's input larger than the frequency of channel B's input. If the frequency of channel A input is smaller than that of channel B, measurement is possible provided that the multiplier is increased (when the multiplier = 1, 0 is displayed as the measurement).
- **Input frequency range**
Channels A and B: 1 mHz to 60 MHz
- **Measuring range**
0.001 to 999999999
- **Resolution**

$$\frac{\pm A \text{ input } 1 \text{ count} \pm \sqrt{2} \times B \text{ input trigger error}}{10^N} \text{ [s]} \quad (10^N \text{ denotes the multiplier, } N = 0, 1, 2, \text{ or } 3)$$

- The resolution varies with the multiplier setting, trigger error, ±1 count error, etc. For details, see Section 4.12, "Measurement Accuracy" (page 4-15).
- **Measurement timing (if slope A = ↘ and slope B = ↗)**

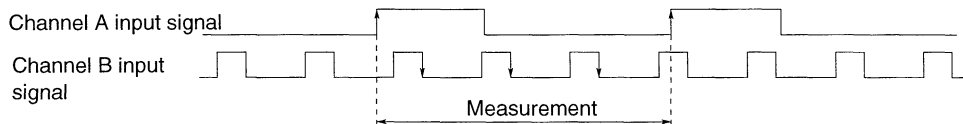

Operation Procedure

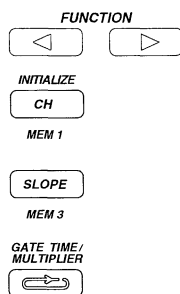

- Setting measurement function**
Select **CHA**, **CHB**, and **RATIO** by pressing the **FUNCTION** key.
- Selection of the channel in which the slope is to be set**
Select **CHA** or **CHB** by pressing the **CH** key.
- Setting slope**
Select ↗ or ↘ by pressing the **SLOPE** key.
- Carry out steps 2 and 3 for both channels A and B.
- Setting multiplier**
Select either **1**, **10**, **100**, or **1000** by pressing the **GATE TIME/MULTIPLIER** key.
For multipliers, see Section 3.2, "Setting Gate Time/ Multiplier" (page 3-8).

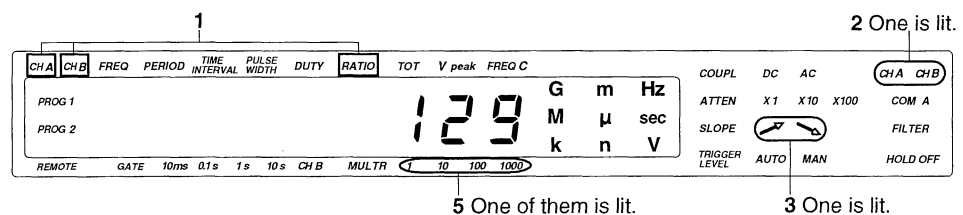

4.7 Peak-voltage Measurement

Before Operation

- **Channels to be measured**
Channels A and B
- **Measuring method**
Measure the maximum and minimum input signal voltages.
- **Measuring range**
-5 V to +5 V (ATTEN × 1)
-50 V to +50 V (ATTEN × 10)
-250 V to +250 V (ATTEN × 100)
- **Dynamic range**
250 mV p-p to 5 V p-p (for ATTEN × 1)
- **Input frequency range**
50 Hz to 20 MHz
- **Resolution in measurement**
20 mV (ATTEN × 1)
200 mV (ATTEN × 10)
2 V (ATTEN × 100)

Operation Procedure



- **Setting measurement function**
Select either **CHA** and **Vpeak** or **CHB** and **Vpeak** by pressing the **FUNCTION** key.

Either Vpeak and CHA or Vpeak and CHB are lit.

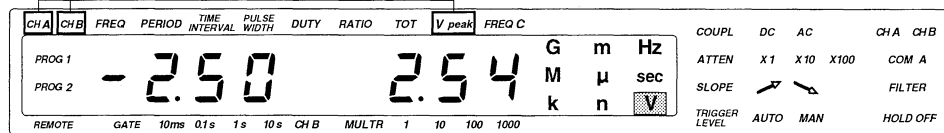

The minimum value

The maximum value

4.8 Totalized-count Measurement

Before Operation

- **Channel to be measured**
Channel A

- **Input frequency range**
1 mHz to 50 MHz

- **Counting capacity**
0 to 999999999

- **Procedure for totalization start/stop and measurement timing**

1. Manual operation

When the **START** key is pressed, the totalized value at that point is reset and counting starts at 0. Totalization holds when the **DISP HOLD** key is pressed. When the key is pressed again, totalization restarts at the value before holding.

- **Measurement timing (if slope is ↗)**

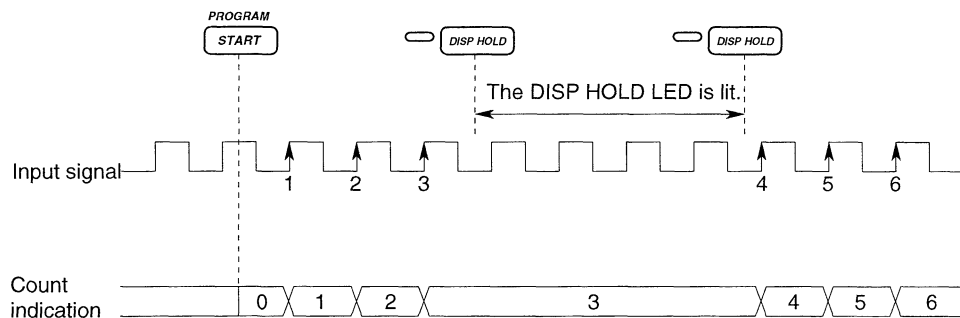

2. Using the channel B input signal as a gate

- The channel A input frequency range changes to 1 mHz to 50 MHz.
- When the channel B slope is ↗ (upward), totalization is executed while the channel B input is high.
- When the channel B slope is ↘ (downward), totalization is executed while the channel B input is low.

- **For DISP HOLD = OFF**

When a gate input is applied, the number of pulses while the gate is open is totalized starting at 0 and is displayed. At the time the gate is closed, the totalized value is reset to 0.

- **Timing of measurement (if SLOPE is A = ↗ and B = ↗)**

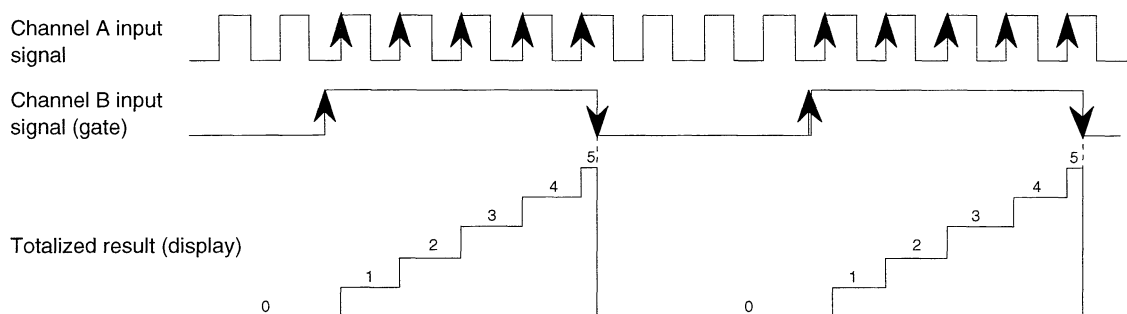

• For DISP HOLD = ON

When the **START** key is pressed, the totalized value is reset to 0, and when the gate input is applied, the number of pulses is totalized while the gate is open and is displayed. At the time the gate is closed, totalization stops and the totalized value holds.

To make a measurement, press the **START** key again.

• Timing of measurement (if SLOPE is A = ↗ and B = ↘)

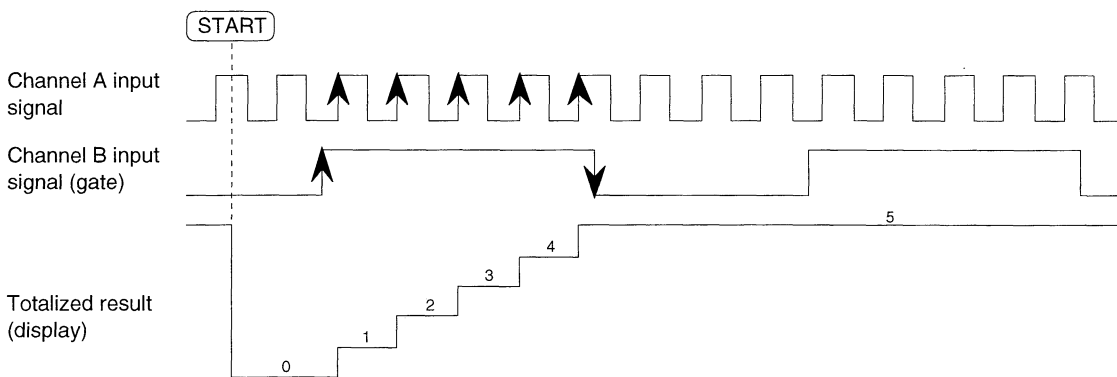

Operation Procedure

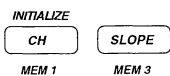
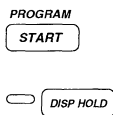
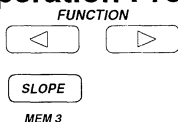

1. Setting measurement function

Select **CHA** and **TOT** by pressing the **FUNCTION** key.

2. Setting channel A slope

Select ↗ or ↘ by pressing the **SLOPE** key.

• Manual operation

3. Execute totalization from the beginning (reset)

Press the **START** key.

4. Totalization hold/restart

Totalization holds when the **DISP HOLD** key is pressed. By pressing **DISP HOLD** key again, totalization restarts at the value before the totalization held.

• Using channel B input signal as a gate

3. Measurement of gate time

Select **CHB** by pressing the **GATE TIME/MULTIPLIER** key. There is no other gate setting.

For gate time, see Section 3.2, “Setting Gate Time/Multiplier” (page 3-8).

4. Set channel B slope.

(1) Select **CHB** by pressing the **CH** key.

(2) Select ↗ or ↘ by pressing the **SLOPE** key.

5. Totalization hold/restart

Totalization holds when the **DISP HOLD** key is pressed. By pressing **DISP HOLD** key again, totalization restarts.

For operation of the display-hold function, see Section 4.11, “Holding Display” (page 4-14).

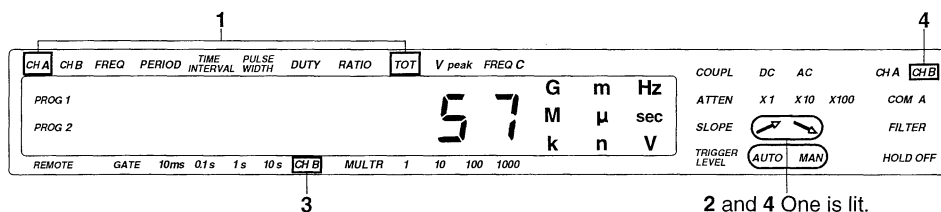

Note

- If totalization is executed in manual operation, the slope can only be set in channel A. The CH key is not operable.
- If the totalized value exceeds the counting range, error code 301 is displayed.

4.9 Measurement of Number of Revolutions (for TC110 counter only)

Before Operation

- **Channel to be measured**
Channel B
- **Measuring method**
The frequency in channel B is measured and the value obtained is displayed after being multiplied by 60.
- **Measuring range**
60 mrpm to 120 Mrpm
- **Resolution in measurement**

$$\frac{\pm 10\text{ns} \pm \sqrt{2} \times \text{Trigger error}}{\text{Gate time}} \times \text{Measured number of revolutions [rpm]}$$

- The resolution varies with the multiplier setting, trigger error, ± 1 count error, etc. For details, see Section 4.12, "Measurement Accuracy" (page 4-15).
- **Measurement timing (if slope is ↘ (downward))**

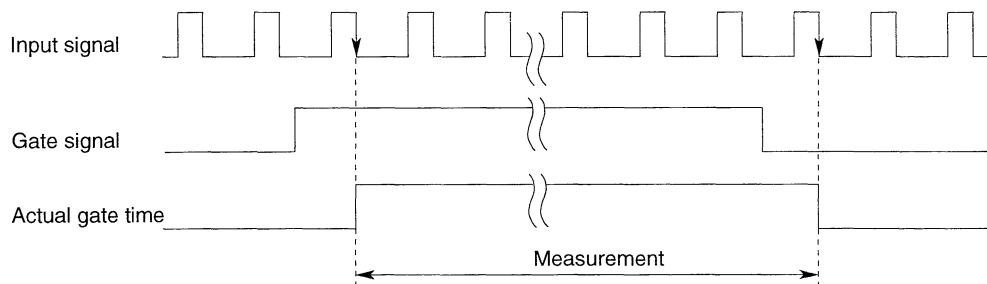

Operation Procedure

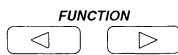

1. Setting measurement function

Select **CHB** and **rpm** by pressing the **FUNCTION** key.



2. Setting channel B slope

Select either ↗ or ↘ by pressing the **SLOPE** key.

MEM 3

GATE TIME/
MULTIPLIER



3. Setting gate time

Select either **10 ms**, **0.1 s**, **1 s**, or **10 s** by pressing the **GATE TIME/MULTIPLIER** key.

For gate time, see Section 3.2, "Setting Gate Time/ Multiplier" (page 3-8).

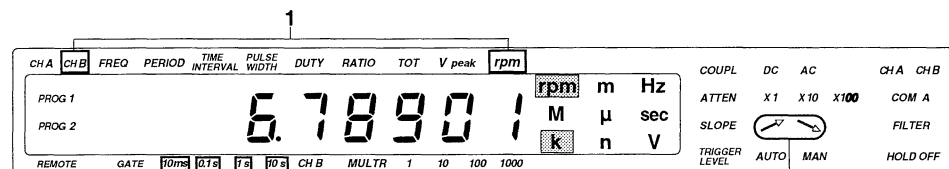

3 One of them is lit.

2 One is lit.

Note

If the number of revolutions is to be measured using the TC120 counter, use the scaling function. For this function, see Subsection 5.6.1, "Scaling" (page 5-12).

4.10 Changing Display Readout (Measured value, Trigger Level, and Hold-off Time)

Before Operation

- **Change of display readout**

The displayed measurement, trigger level, and hold-off time can be changed.

- **Trigger level display**

The trigger level for the currently selected channel is displayed. When the trigger mode is in automatic, the display reads “trig.AUto”

- **Hold-off time display**

The hold-off time for the currently selected channel is displayed. When the hold-off setting is disabled, the display reads “h.oFF oFF”

For setting the hold-off time, see Section 5.2, “Using Hold-off Function” (page 5-4).

Operation Procedure

UTILITY
DISPLAY

When the **DISPLAY** key is pressed, readout follows the order of measurement display → the BIN judgment (only when the handler is ON) → trigger level → hold-off time.

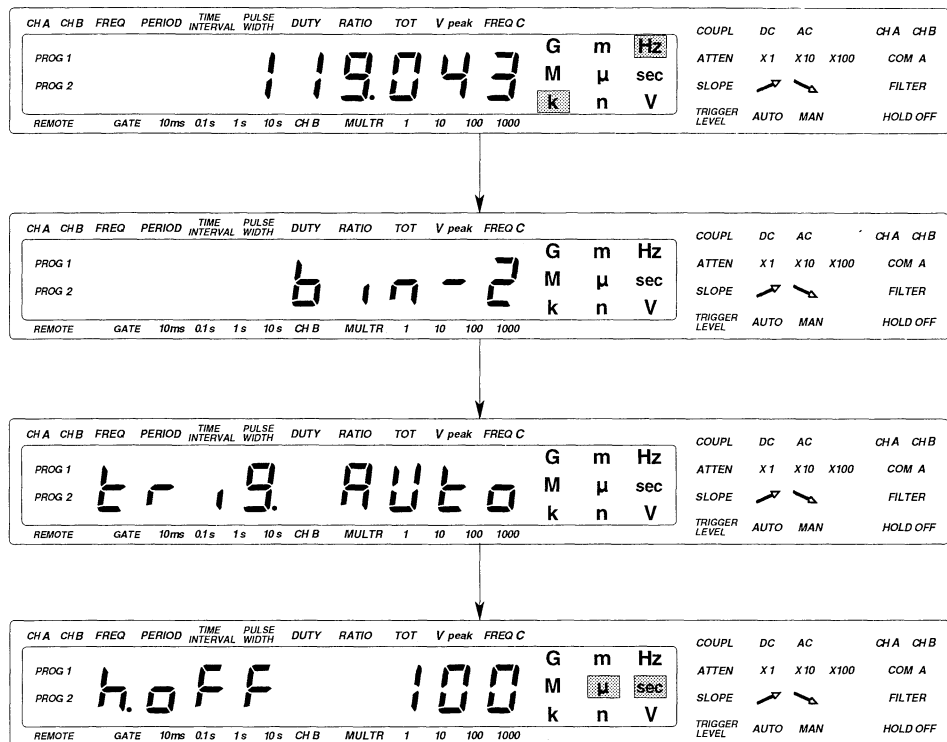

Note

In a measurement readout, as soon as the measurement is finished, it appears on the display. Thus, during the trigger waiting status or measurement, “-----” is displayed.

4.11 Holding Display

Before Operation

- **Display-holding function**
 - Measurement readout holds (measurement is also stopped at the same time).
 - If the **START** key is pressed while the **[DISP HOLD]** LED is lit, a one-shot measurement can be made at every press of the key. (However, if the measurement function is set to “totalized counting,” the start is executed after resetting the totalized value.)
- **Action**

When the display is holding, the **[DISP HOLD]** LED is lit. However, if the measurement function is changed during this time, holding is released.
- **Measurement timing (for period measurement)**

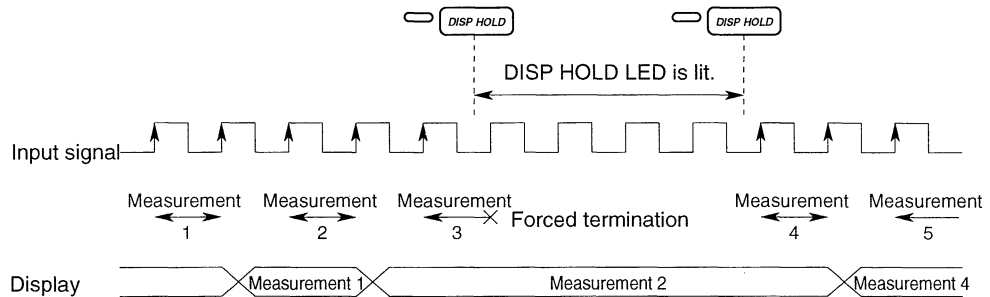

Operation Procedure



1. Press the **DISP HOLD** key.
The **[DISP HOLD]** LED is lit and the display stops.
2. When the **DISP HOLD** key is pressed once more, measurement restarts.

4.12 Measurement Accuracy

Factors Determining Counter Accuracy in Measurement

Accuracy expresses to what degree a measurement deviates from its true value. Factors causing such deviation include the following:

$$\text{Accuracy} = \pm \text{resolution} + \text{timebase error} \pm \text{trigger level timing error} \dots (1)$$

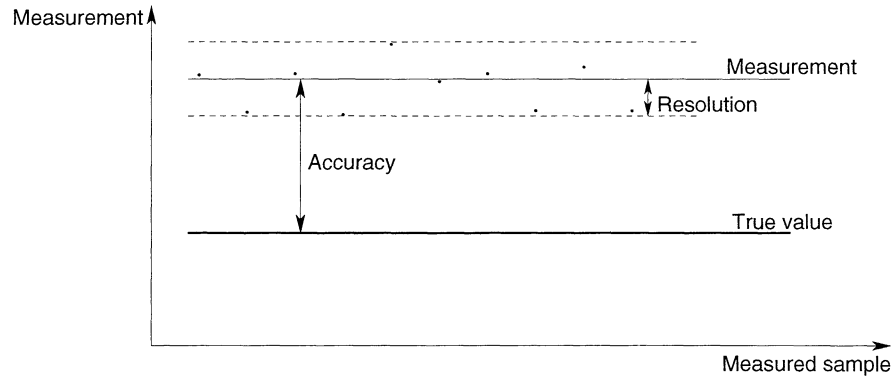

Factors Determining Counter Resolution

Resolution is the smallest difference between which two adjacent measurements can be identified and is determined by the following factors in time measurement in counters, such as frequency and time interval measurement.

$$\text{Resolution} = \pm 1 \text{ count error} \pm \text{trigger error} \dots (2)$$

- **± 1 count error**

Since the counter internal clock for measuring time is asynchronous with input signals, a quantization error by ± 1 clock count is generated depending on the timing between them. The timing for two input signals with a clock are shown below. Although the pulse width is the same in input signals 1 and 2, the difference by one clock count is generated due to the position of the timing.

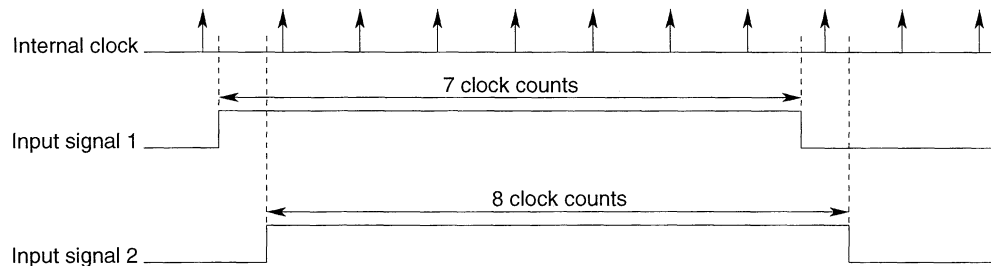

• **Trigger Error**

In input signals having slow rises, such as random noise superimposition on the input signal or sinusoidal waves of low frequencies, the timing that traverses the trigger level varies with each measurement. Such dispersion causes a measurement error called a trigger error.

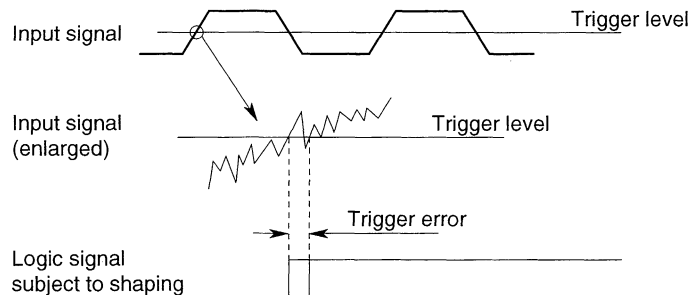

If noise is superimposed on the input signal as shown above, the signal noise causes a trigger error in the signals having a slow rise. The relationship between the trigger error and the signal noise is expressed as shown below using the signal slew rate ($SR = \Delta V/\Delta t$).

$$\text{Trigger error [srms]} = \frac{\sqrt{X^2 + E_n^2} \text{ [Vrms]}}{S. R \text{ [V/s]}} \quad \dots(3)$$

(X: Counter input block noise; E_n : Signal noise)

In addition, $X = 600 \mu\text{V rms}$ (typical) in TC100 series counters.

Gate Time and Resolution

Two factors (± 1 count error and trigger error) are included in equation (2) for resolution on page 4-15. The ± 1 count error corresponds to 10 ns for TC100 series counters. If a sufficiently fast rise signal is considered, the resolution can be expressed with only the ± 1 count error because the trigger error can be ignored.

In the TC110/120 counters that employ the reciprocal frequency counting method, when the frequency is measured using gating, the resolution is improved in proportion to the gate time because the resolution is averaged with the frequency of the signal input within the gating time. Expressing this in an equation, the resolution in frequency measurement (± 1 count error) is expressed as shown in equation (4).

$$\text{Resolution in frequency measurement} = \frac{\pm 10\text{ns}}{\text{Gate time}} \times \text{Measuring frequency} \quad \dots(4)$$

This means that the significant digits are determined by the single-shot time resolution of 10 ns and the gate time, and the resolution can be calculated by multiplying the measuring frequency. If the gate time is set to 1 second, there are eight significant digits. The following shows the relationship between the input frequency and the frequency resolution (least significant digit) for a gate-time parameter.

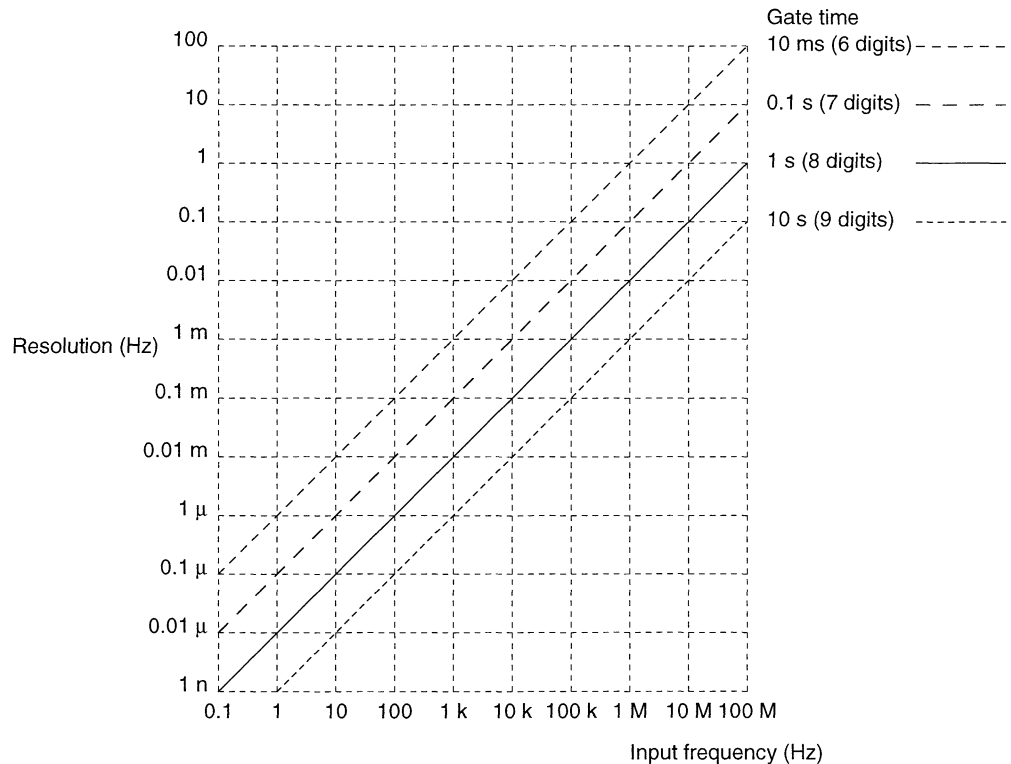

Multiplier

In a time measurement other than frequency, such as period or time interval, the resolution is improved not by gating but by increasing the multiplier. That is, the resolution is improved by determining the average value after measuring the time for succeeding N periods. The following shows a timing chart using the multiplier of 10 in a period, pulse width, time interval, or duty ratio measurement.

For frequency measurement

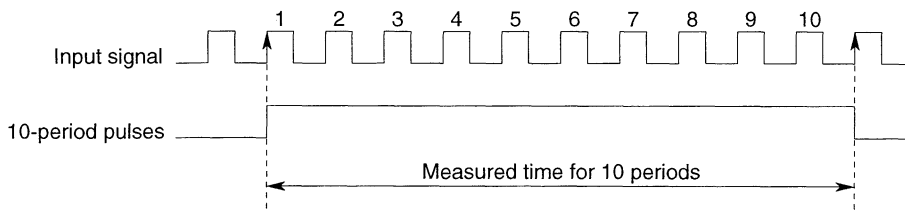

For pulse width, time interval, and duty ratio measurement

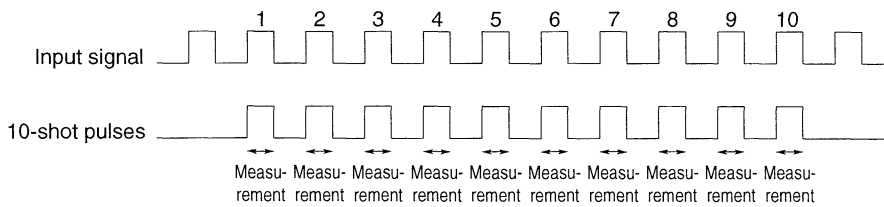

In period measurement, if the multiplier is set to 10, collectively measure the time for ten input pulses. Since measuring edges are limited to two, at the first and 11th pulses, averaging by dividing by 10 improves the resolution ten-fold because a measurement error due to the edges between the above two pulses is reduced.

However, in time interval, pulse width, and duty ratio measurements, the resolution is not simply improved ten-fold even though the multiplier is increased to 10 because ten pulses are individually measured and averaged. As the averaged value is that of independent pulses, resolution is only improved to the $\sqrt{10}$ times.

Timebase Error

The oscillation period of the internal crystal oscillator is used for the reference for measurement of time.

The oscillation frequency of the crystal oscillator is subject to aging. Since the aging rate of the crystal oscillator used in a TC100 series counter is $\pm 1.5 \times 10^{-6}$ /year, an oscillation frequency of 10 MHz may possibly vary by as much as 15 Hz after one year. An error caused by a shift in the reference frequency is called a timebase error.

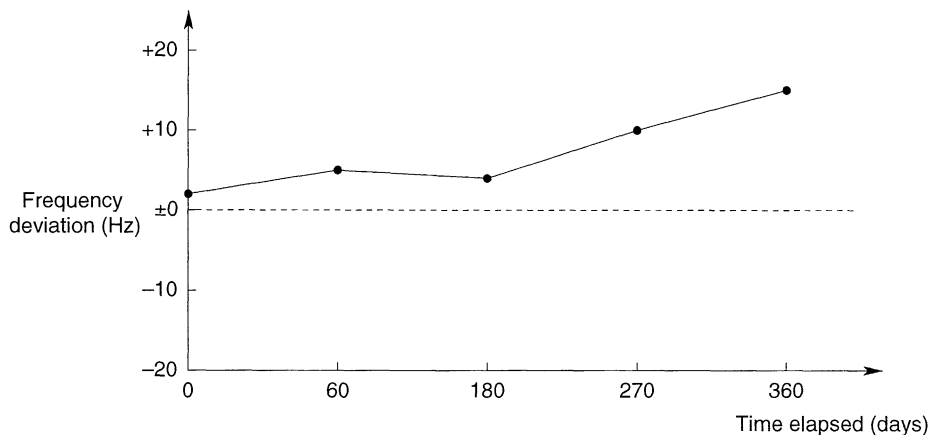

For example, if it is assumed that there is a period measurement of 1 ms after a year, the timebase error at that time will be $(1.5 \times 10^{-6}/\text{year}) \times 1 \text{ year} \times 1 \text{ ms} = 1.5 \text{ ns}$.

Trigger-level Timing Error

The trigger-level timing error is a measurement error generated in time interval, pulse width, or duty ratio measurements, due to the accuracy of the trigger level setting and/or the difference between the rise and fall of channels A and B or the slopes.

An example of a time interval measurement is shown below. The trigger level is provided with hysteresis as a measure against noise. This causes a timing error. That is, the trigger is applied at a higher level than the set voltage at a signal rise and if the signal rise is slower, triggering is delayed by a value corresponding to the hysteresis band.

If the rise times are different between the rises for start and stop, the trigger-level setting accuracy also causes a timing error.

The errors due to the hysteresis band and the trigger-level setting accuracy are together called the trigger-level timing error. By expressing the rise time in the slew rate of the signal S.R. [V/ μ s], the trigger-level timing error can be calculated by the following equation:

$$\text{Trigger-level timing error} = \left(\frac{1/2 \text{ hysteresis band}^*}{\text{S.R. (Start)}} - \frac{1/2 \text{ hysteresis band}^*}{\text{S.R. (Stop)}} \right) \\ \pm \frac{\text{Trigger-level setting accuracy}}{\text{S.R. (Start)}} \pm \frac{\text{Trigger-level setting accuracy}}{\text{S.R. (Stop)}}$$

S.R.: Input signal slew rate at the trigger level
* Hysteresis band is 20 mV for ATTEN \times 1.

If the rise time of the channel B input signal is longer than that of channel A input signal, the measured time interval is as shown below.

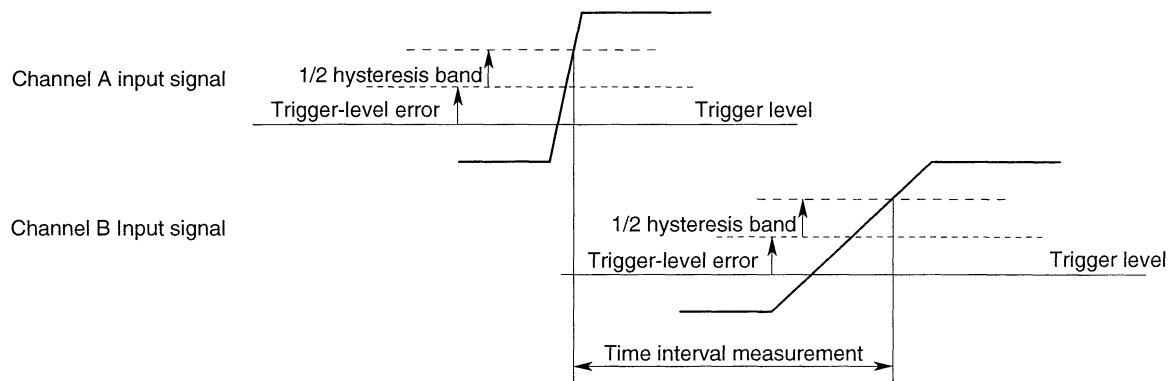

Chapter 5

OTHER FUNCTIONS

5.1	Storing/Recalling Settings	5-2
5.2	Using Hold-off Function	5-4
5.3	Initializing Settings	5-6
5.4	Making Input Common to Channels A and B	5-7
 5.5	Using External Reference Signal Input and Reference Signal Output	5-8
5.6	Utilities	5-10
5.6.1	Scaling	5-12
5.6.2	Using Displayed-digit Masking Function	5-13
5.6.3	Checking Reference Signal/Software Version	5-14
5.6.4	Digital/Analog Conversion Output (optional function)	5-15
5.6.5	Using the Handler Interface (optional function)	5-17

5.1 Storing/Recalling Settings

Before Starting

- **Storing function**

Current settings are stored in the non-volatile memories. There are eight memories (MEM1 to MEM8) and this allows a storage memory to be selected. The stored settings are retained after the power is turned off.

- **Setting information to be stored**

- | | | | |
|-----------------------------|-------------------------|-------------------------|------------|
| • Measurement functions | • Gate time | • Multiplier | • Slope |
| • Coupling | • Attenuator | • Filter | • Hold-off |
| • Trigger level | • COM A | • SCALE1 | • OFFSET1 |
| • SCALE2 | • OFFSET2 | • Display digit masking | |
| • Scaling setting | | | |
| • D/A output* | • D/A minimum value* | • D/A maximum value* | |
| • Handler Interface on/off* | • Handler set1 to set4* | • Handler t.out* | |
- * denotes an optional function.

- **Caution when storing**

When the key for the memory in which settings are already stored is pressed, the settings are automatically updated with the new data. Exercise care when storing.

- **Recall function**

- This function recalls stored settings. Current settings are replaced with the recalled settings.
- When recall is executed, the display changes to a measured value and the **DISP HOLD** function turns off.

Operation Procedure

Storing



1. Press the **STORE (SHIFT+RECALL)** key. "StorE" appears on the display.

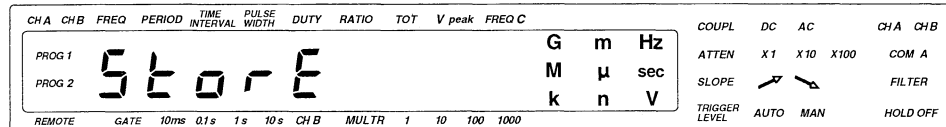

2. Press the key for the memory which is the destination for storing. The memory number is indicated on the display and storing is carried out. When the operation is completed, the display indicates the original measurement.

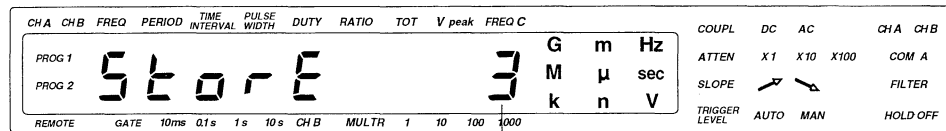

Memory number

Recalling



- 1. Press the RECALL key. "rEcALL" appears on the display.

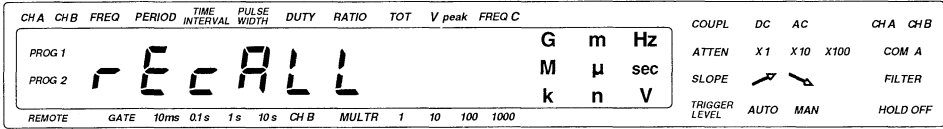

- 2. Press the key for the memory from which the settings are to be recalled. That memory number is indicated on the display, recalling is carried out, and the setting is updated.

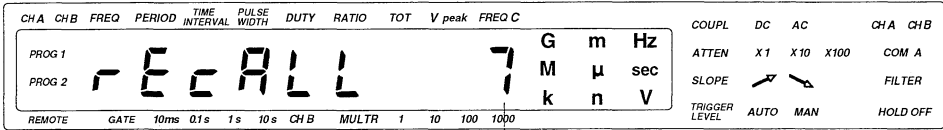

Memory number

Note

To discontinue the store/recall function, press any key except MEM1 to MEM8.

5.2 Using Hold-off Function

Before Starting

- **Hold-off function**

- The function which ignores input signals only for 100 μ s to 10 ms after the first edge of the input signal is detected.
- It is effective for measuring a signal which contains noise whose generation is predictable or chattering noise.
- Set the hold-off time for each measurement function because the setting is retained for each measurement function.

- **Setting range**

- 100 μ s to 1 ms : 100 μ s step
- 1 ms to 10 ms : 1 ms step
- 10 ms to 100 ms : 10 ms step

- **Measurement functions for which the hold-off function can be used and measurement timing**

Measurement function		
CHA FREQ	- ..	o ... Hold-off function provided
CHB FREQ	o .. (1)	- ... Hold-off function not provided
PERIOD	o .. (2)	
TIME INTERVAL	o .. (3)	
PULSE WIDTH	o .. (4)	
DUTY	o .. (5)	
RATIO	-	
TOT	o .. (6)	
V _{peak}	-	
FREQ C(TC120)	-	
rpm(TC110)	o .. (7)	

(1) CHB FREQ (for SLOPE of ↗)

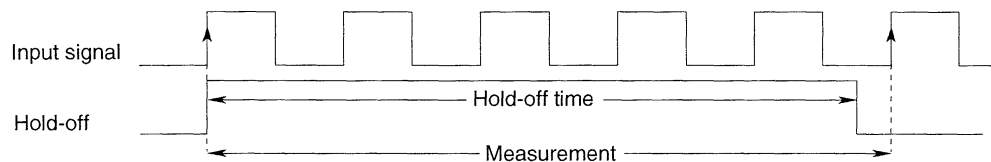

(2) PERIOD (for SLOPE of ↗)

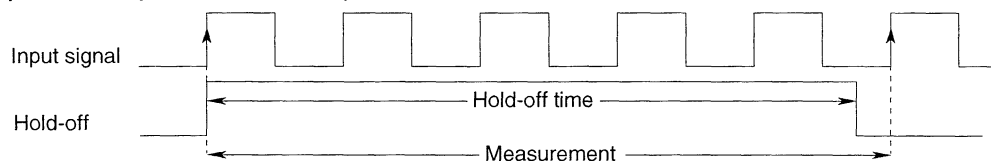

(3) TIME INTERVAL (for SLOPE of A = ↗ and B = ↗)

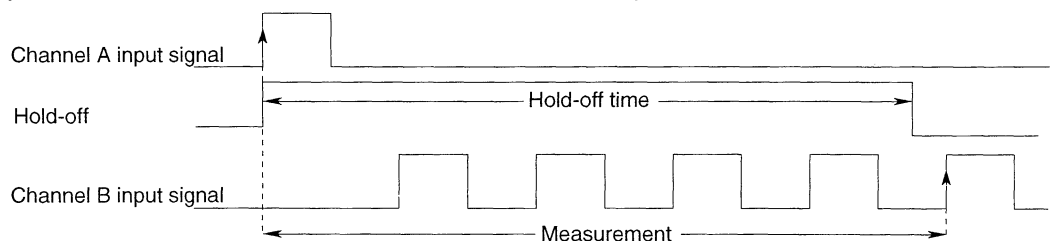

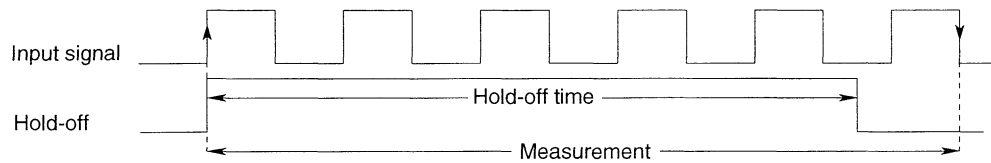
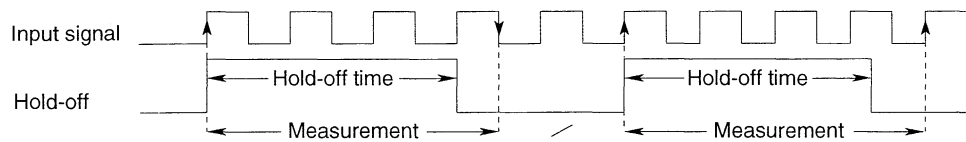
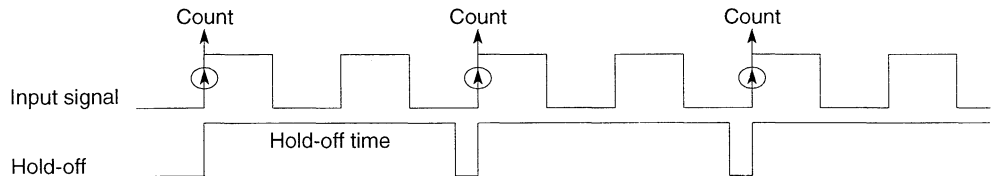
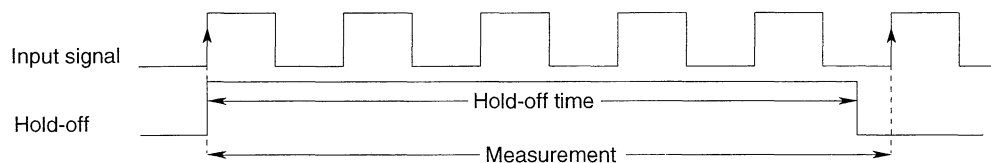
(4) PULSE WIDTH (for SLOPE of ↗)**(5) DUTY (for SLOPE of ↗)****(6) TOT (for SLOPE of ↗)****(7) rpm (for SLOPE of ↗)****• Caution when using the hold-off function**

When the hold-off function is to be on, the multiplier is fixed to “×1” and cannot be changed. If the multiplier is to be changed, turn the hold-off function off.

Operation Procedure

1. Press the **HOLD OFF** key.

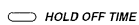
**2. Setting the hold-off time**

- If the **[HOLD OFF TIME]** LED is not lit (**TRIGGER LEVEL** is lit), press the **HOLD OFF** key again.

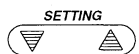

- Set the time using the **SETTING** key. (the **SETTING** key is effective when the **[HOLD OFF TIME]** LED is lit.)
Pressing \blacktriangle increases the numeric value and pressing \blacktriangledown , decreases it.

Note

Pressing the DISPLAY key enables the current hold-off time to be checked. Also, if the HOLD OFF LED is lit, the time can be changed with the SETTING key. However, if the hold-off time is off, only “H.OFF OFF” appears on the display.

5.3 Initializing Settings

Before Starting

- **Initialization**

Restoring the settings to those set upon shipment from the factory is called initialization.

- **Initialized settings**

Item	Initialized setting
Measurement function	CHA FREQ
Gate time	10 ms
Multiplier	1
Slope	↗
Coupling	DC
Attenuator	Á1
Filter	OFF
Hold-off	OFF
Hold-off time	100 µs
Trigger mode	AUTO
COM A	OFF
SCALE1	1.0
OFFSET1	0.0
SCALE2	1.0
OFFSET2	0.0
Display digit masking	0
DISPLAY	Measured value display
DISP HOLD	OFF
Scaling setting	OFF
D/A output	OFF
D/A minimum value	0
D/A maximum value	0
Handler setting	OFF
SET1 to 4	0
T.OUT	OFF

- **Items always initialized when power is turned on**

Item	Initialized setting
DISPLAY	Display of Measurement
DISP HOLD	OFF
GP-IB command header	ON
GP-IB return terminator	CR+LF
D/A output	OFF

- **Notice on initialization**

The following items are not initialized:

GP-IB address, Contents of MEM1 to MEM8

Operation Procedure

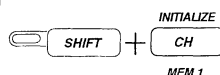

When the **INITIALIZE (SHIFT+CH)** key is pressed, initialization starts.

5.4 Making Input Common to Channels A and B

Before Starting

- **Function**
 - Internally make channel A input common to channels A and B. In this case, the channel B input connector is disconnected from the internal circuit.
 - The period, pulse width, time interval, duty ratio, frequency ratio, and the number of revolutions (for TC110) can be measured for the channel A input signals.
- **Input impedance**
50 k Ω //80 pF (typical)
- **Internal circuit connection**

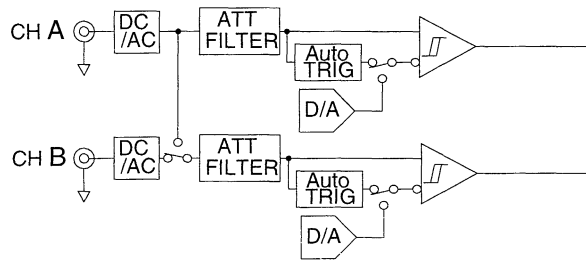

Operation Procedure

COM A
MEM 2

Press **COM A** key to light up the [COM A] LED.

5.5 Using External Reference Signal Input and Reference Signal Output

Before Starting

External Reference Signal Input Function

Although the counter carries out measurement using its internal crystal oscillator signal (10 MHz) as the reference signal, an external input signal can be used as another reference signal by the following operations:

- **Caution on connection**



CAUTION

The input voltage is designed to be 1 V_{p-p} to 7 V_{p-p} and the input impedance 1 k Ω or more. An input voltage exceeding this value may damage the counter.

- **External reference signal input usage**

When a signal within the input voltage levels is input to the REFERENCE IN terminal on the rear panel, the external input signal automatically changes to the reference signal.

- **Input conditions**

- Input impedance : 1 k Ω or more
- Input frequency : 10 MHz \pm 10 Hz
- Input voltage level : 1 V_{p-p} to 7 V_{p-p}
- Duty : 40 to 60% (for rectangular waveform)
- Input terminal : BNC connector

- **Input circuit**

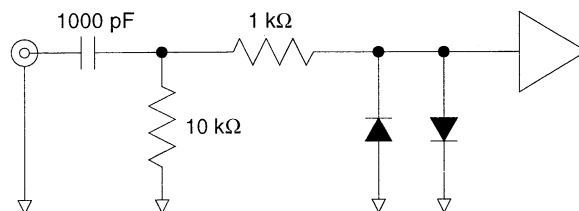

- **Confirmation of reference signal**

- Confirmation of whether the current reference signal is internal or external is performed using the utility menu. For details, see **Subsection 5.6.3, “Checking Reference Signal/ Software Version”** (page 5-14).

Reference Signal Output Function

Reference signals are output from the REFERENCE OUT terminal on the rear panel. When external input signals are used as reference signals, external input signals must be processed according to the following specifications.

- **Caution on connection**



CAUTION

- Do not short-circuit the output terminals or apply the voltage externally. Otherwise, the counter may be damaged.
- Surely connect the output terminal ground to the ground of the connected equipment. Otherwise, the counter may be damaged.

- **Output specifications**

- Output frequency : 10 MHz
- Output voltage : 1 V_{p-p} (50 Ω)
- Output waveform : Rectangular
- Output terminal : BNC connector

- **Output circuit**

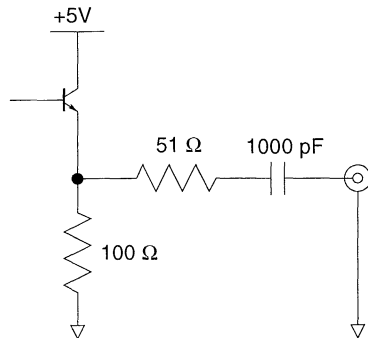

Operation Procedure

Connect the signal to the REFERENCE IN terminal or REFERENCE OUT terminal on the rear panel.

Note

- The reference signal output is always output.
- If the external reference signal input does not meet the input conditions described on the preceding page, the counter automatically operates using the internal reference signal.

5.6 Utilities

Utility

The counter has the following five utility functions. This section describes the numeric value setting method common to each utility. For a description of each utility, see the following pages:

- Scaling function → Subsection 5.6.1 “Scaling” (page 5-12)
- Displayed-digit masking function → Subsection 5.6.2, “Using Display-digit Masking Function” (page 5-13)
- Checking reference signal/software version → Subsection 5.6.3, “Checking Reference Signal/Software Version” (page 5-14)
- D/A output function (optional) → Subsection 5.6.4, “Digital/Analog Conversion Output” (page 5-15)

• Selection of Function

1. Press the **UTILITY (SHIFT+DISPLAY)** key.
“ScALE-1” appears on the display.

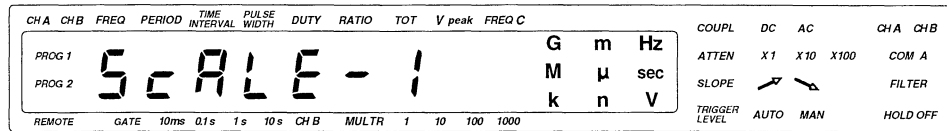

2. When the **SETTING** key ∇ is pressed, the menu changes in the order of [ScALE-1] [oFFSET-1] [ScALE-2] [oFFSET-2] [cUt digit] ([dA oFF] [dA Lo] [dA hi]) ([hdL oFF] [SEt-1] [SEt-2] [SEt-3] [SEt-4] [t.out]) [rEF.int] (rEF.EHt) [rEv 1.01] [ScALE-1]. When the **SETTING** key \triangle is pressed, the menu changes in reverse order.

• Numeric value setting method in each utility function

1. When the **GATE TIME/MULTIPLIER** key is pressed after a function is selected, the numeric value appears on the display. If this key is pressed again, the display returns to the utility menu.
2. The numeric value is set while the digit is flashing. Pressing \triangle key increases the value while pressing ∇ decreases the value. The flashing position is moved with the **FUNCTION** key. Pressing \triangleright key moves the flashing one digit to the right while pressing \triangleleft key moves it one digit to the left.

• Moving unit (only for OFFSET, SET1 to SET4, DA HI, and DA LO)

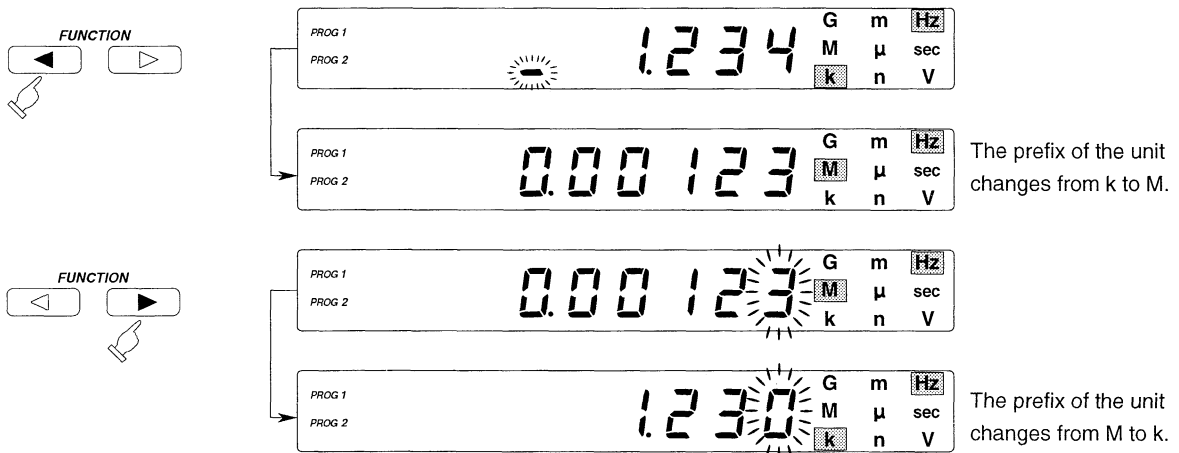

• Positive value setting

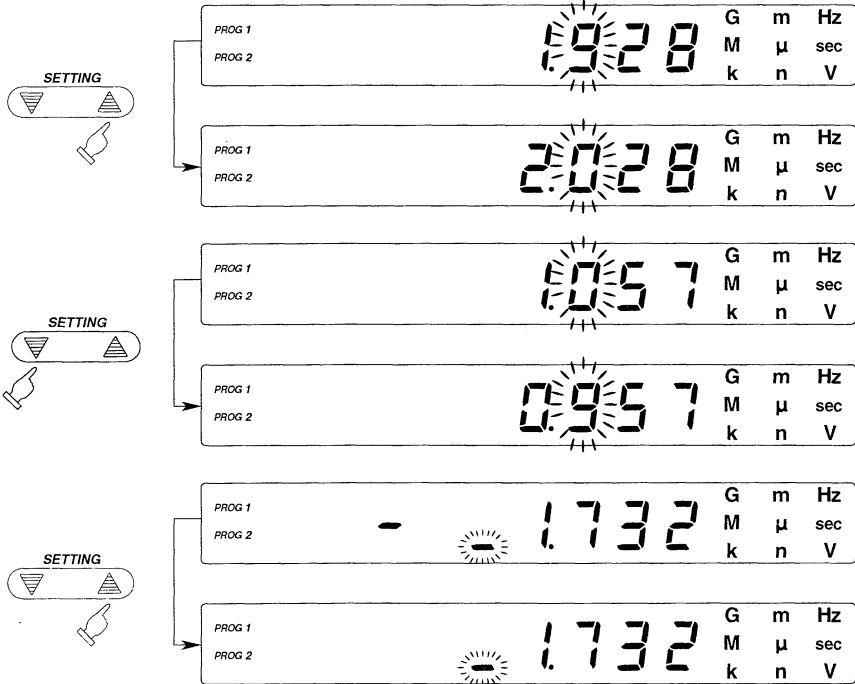

• Negative value setting (1)

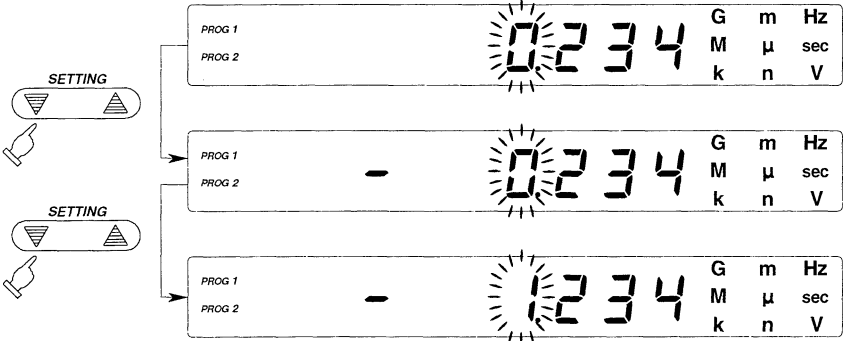

• Negative value setting (2)

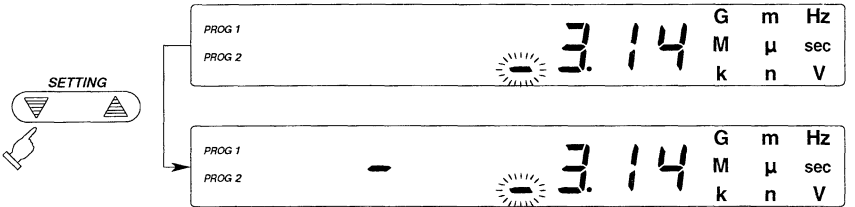

Note

In "negative value setting (2)," if the flashing is shifted one digit to the left, the same operation applies.

5.6.1 Scaling

Before Starting

- **Scaling function**

- Operation with the expression $ax+b$ is performed. Conversion to any physical quantity is possible (x is a measured value) since a and b can be freely set.
- Computational expressions can be set in PROG1 and PROG2. Since settings are stored in internal non-volatile memory, the setting is retained even if the power is turned off.
- If PROG1 or PROG2 is selected using the **PROGRAM** key, measured data are displayed in scaling values. However, in this case, only the prefix of the unit representing powers of ten, that is G, M, k, m, μ , or n is displayed and Hz, sec, and V are not displayed.
- When peak voltages are measured, the scaling function cannot be used.

- **Numeric value setting range**

- a(SCALE) : -999.999 to 999.999
- b(OFFSET) : -999.999M to 999.999M (for TC110)
-999.999G to 999.999G (for TC120)

- **Setting**

Parameters a and b for PROG1 are ScALE-1 and oFFSET-1.
Parameters a and b for PROG2 are ScALE-2 and oFFSET-2.

Operation Procedure

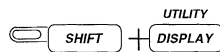

1. Press the **UTILITY (SHIFT+DISPLAY)** key.

Repeat pressing the **SETTING** key until “ScALE-1(2)” or “oFFSET-1(2)” appears on the display.



2. **Numeric value setting**

- Press the **GATE TIME/MULTIPLIER** key (a numeric value is indicated on the display).
- For setting numeric values, set the digit to flashing with the **FUNCTION** key and use the **SETTING** key. For details, see **Section 5.6, “Utilities”** (page 5-10).

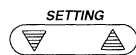

3. **Return to the utility menu display.**

Press the **GATE TIME/MULTIPLIER** key.



4. **Exit from the utility menu.**

Press a key other than the **FUNCTION**, **GATE TIME/MULTIPLIER**, or **SETTING** key. The display indicates the measurement.

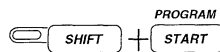

5. **Display a measurement as the scaling value.**

Select PROG1 or PROG2 by pressing the **PROGRAM (SHIFT+START)** key.

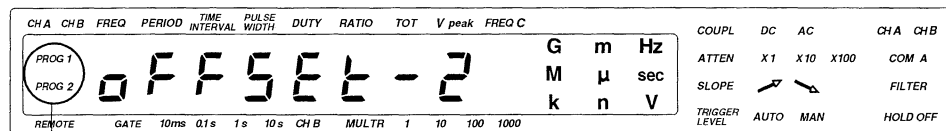

5 One is lit.

5.6.2 Using Displayed-digit Masking Function

Before Starting

- **Displayed-digit masking function**

Any number of the least significant of the nine digits displayed can be masked. The display of unnecessary digits can be eliminated.

- **Setting range**

0 to 9

Operation Procedure

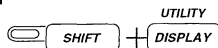

1. Press the **UTILITY (SHIFT+DISPLAY)** key.

Repeat pressing the **SETTING** key until “cUT digit” appears on the display.

2. **Set the number of digits to be masked.**

- Press the **GATE TIME/MULTIPLIER** key (a numeric value is indicated on the display).

- Set the number of digits to be masked using the **SETTING** key.

3. **Return to the utility menu display.**

Press the **GATE TIME/MULTIPLIER** key.

4. **Exit from the utility menu.**

Press a key other than the **FUNCTION**, **GATE TIME/MULTIPLIER**, or **SETTING** key. The display indicates the measurement.

CHA	CHB	FREQ	PERIOD	TIME INTERVAL	PULSE WIDTH	DUTY	RATIO	TOT	V _{peak}	FREQ C	COUPL	DC	AC	CHA	CHB
PROG 1											G	m	Hz		
PROG 2											M	μ	sec		
											k	n	V		
REMOTE	GATE	10ms	0.1s	1s	10s	CHB	MULTR	1	10	100	1000	TRIGGER LEVEL	AUTO	MAN	HOLD OFF

5.6.3 Checking Reference Signal/Software Version

Before Starting

- **Function to check the reference signal/software version**
- Displays whether the currently used reference signal is internal or external.
- The software version number of this counter is displayed. If an inquiry is made because of failure, inform us of this version number.

Operation Procedure

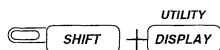

1. Press the **UTILITY (SHIFT+DISPLAY)** key.

- Repeat pressing the **SETTING** key until “rEF.int” (the internal reference signal), “rEF.EHt” (the external reference signal), or “rEv 1.01” appears on the display.
- The reference signal or the version number is displayed.

2. Exit from the utility menu.

Press a key other than the **FUNCTION, GATE TIME/MULTIPLIER**, or **SETTING** key. The display indicates the measurement.

CHA	CHB	FREQ	PERIOD	TIME INTERVAL	PULSE WIDTH	DUTY	RATIO	TOT	V peak	FREQ C	COUPL	DC	AC	CHA	CHB
PROG 1											G	m	Hz		
PROG 2		r	E	F.							M	μ	sec		
											k	n	V		
REMOTE	GATE	10ms	0.1s	1s	10s	CHB	MULTR	1	10	100	1000	TRIGGER LEVEL	AUTO	MAN	HOLD OFF

5.6.4 Digital/Analog Conversion Output (optional function)

Before Starting

- **D/A output function**

This function converts all measurements except peak voltage to voltages of 0 to 10 V and sends out analog outputs.

- **Setting range**

D/A output HI/LO : 0.00001 n to 999.999 M (TC110)
0.00001 n to 999.999 G (TC120)

- **Setting**

- Set a measurement corresponding to 0 V ([**dA Lo**]) and a measurement corresponding to 10 V ([**dA hi**]).
- If the input is smaller than the LO value, the input is converted to 0 V. If the input is larger than the HI value, the input is converted to 10 V.
- Set the HI and LO values for each measurement function.

- **Example**

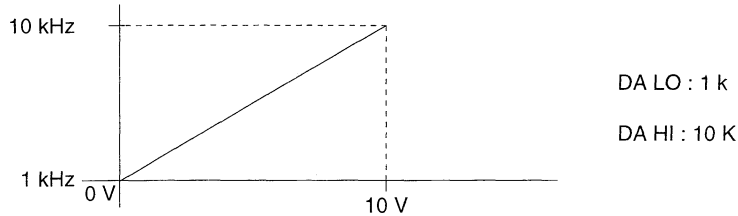

- **Specifications**

- Range setting range : Set both the maximum and minimum values in the range of D/A conversion in six digits.
- Response time : 4 ms or more
- Output terminal : BNC connector

Operation Procedure

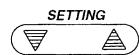
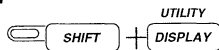

1. Press the **UTILITY (SHIFT+DISPLAY)** key.

- Repeat pressing the **SETTING** key until “**dA Lo**” or “**dA hi**” appears on the display.

2. **Value setting**

- Press the **GATE TIME/MULTIPLIER** key. (A numeric value is indicated on the display.)
- Set the numeric value by setting the digit to flashing with the **FUNCTION** key and using the **SETTING** key. For details, see **Section 5.6, “Utilities” (page 5-10)**.

GATE TIME/
MULTIPLIER



SETTING



GATE TIME/
MULTIPLIER



3. Output

- Press the **GATE TIME/MULTIPLIER** key to return to the utility menu display.
- Repeat pressing the **SETTING** key until “**dA oFF**” appears.
- Display “**dA on**” using the **GATE TIME/MULTIPLIER** key.

4. Exit from the utility menu.

Press a key other than the **FUNCTION**, **GATE TIME/MULTIPLIER**, or **SETTING** key. The display indicates the measurement.

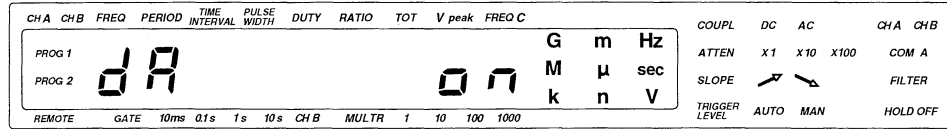

5.6.5 Using the Handler Interface (optional function)

Before Operation

Handler Interface Function

This is a comparator function which sorts all measured values except peak voltages into five ranks. Combination of this function with the component handler or a programmable controller allows an automation system for inspecting and discriminating between components to be constructed.

Operation

The use of the function differs in totalization and the other functions.

- Normal mode All functions except for totalization and peak voltage measurement
- Totalization mode Totalization (except the CHB gate)

• Normal Mode

Measurement starts when the START key is pressed or when either the external trigger signal, START command (GP-IB), or device trigger (GP-IB) is input. In this case, the measuring cycle end signal (EOM) becomes false.

When measurement is completed, the measured values are sorted into a maximum of five ranks by four delimiting values (SET1 to SET4) set up in advance, and the results are output to the signal lines (LOW, BIN1, BIN2, BIN3, and HIGH).

Subsequently, EOM is made true to complete one measurement.

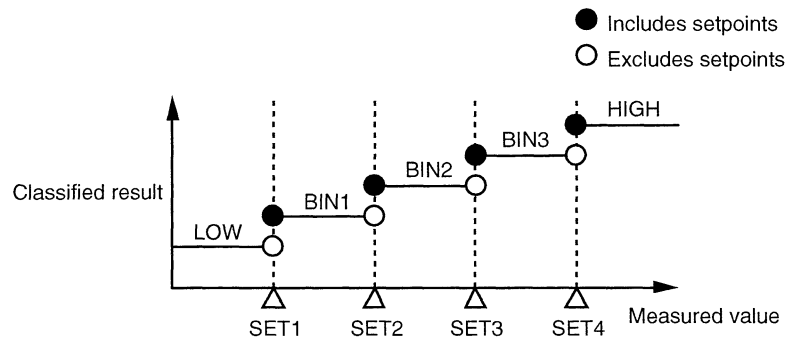

• Totalization Mode

Totalization starts when the START key is pressed or when either the external trigger input signal, START command (GP-IB), or device trigger (GP-IB) is input. In this case, EOM becomes false.

When the totalized value is equal to the discrimination setpoint (SET1) set in advance, the exceeding level signal (HIGH) is output to the signal line.

Subsequently, EOM is made true to complete one measurement.

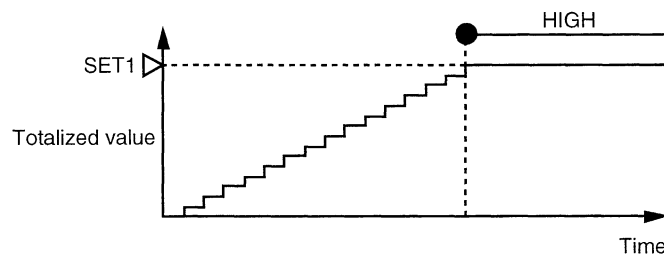

Timeout Operation

If a timeout is preset, measurement is forcibly aborted if the measurement is not completed within this timeout after its start, and the EOM is made true. (LOW, BIN1, BIN2, BIN3, and HIGH remain in false states.)

If the timeout operation is not used, set the timeout time at “OFF.” (the default is OFF). Note that the setting of the timeout is approximate and, therefore, not an accurate value.

Setting Range

Setpoint	SET1 to SET4	0.00001n to 999.999M (for TC110) 0.00001n to 999.999G (for TC120)
Timeout	T.OUT	10 ms, 20 ms, 50 ms, 100 ms, 200 ms, 500 ms, 1 s, 2 s, 5 s, 10 s, 20 s, 50 s, 100 s, 200 s, and OFF

Display of Judgment Result

Pressing the “DISPLAY” key switches the display in the order of the measured value → the BIN judgment result → the trigger level → the hold-off time. However, the BIN judgment result is displayed only when the handler is ON. The result is displayed with “Lo,” “bin-1,” “bin-2,” “bin-3,” “high,” or “t.out.”

Setting Variation in Normal Mode

- For classification into 2

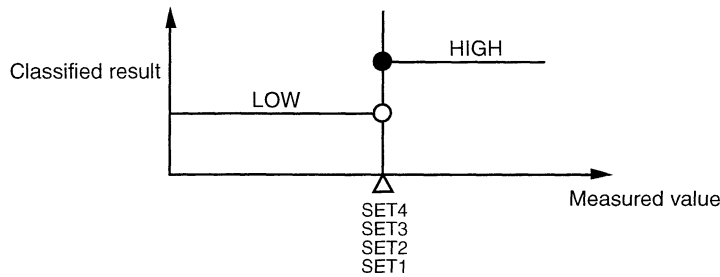

- For classification into 3

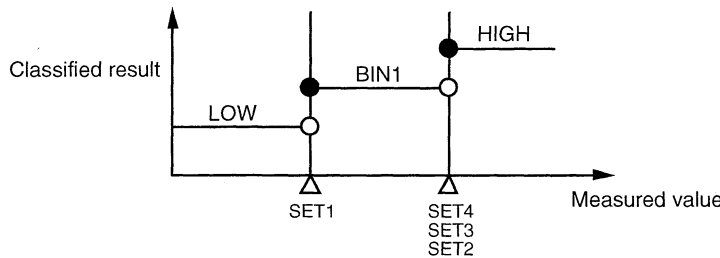

- For classification into 4

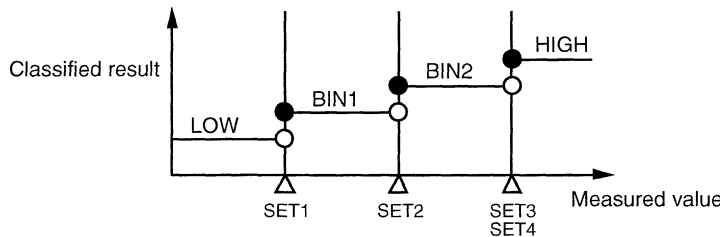

Note

When the operation of the handler is set to ON, a temporary measurement halt status is obtained (DISP HOLD lamp is lit). Note that, in this case, pressing the DISP HOLD key does not release the halt status. To release the halt status, set the handler to OFF.

Signal Line

Interface signals comprise

- Judgment output signal (/BIN1, /BIN2, /BIN3, /LOW, or /HIGH)
- Handshake signal (/EXT_TRIG or /EOM (End of Measurement))
- Power signal (DCV or COM).

Pin	Signal number	Function name
1	COM	External DC voltage common
2	/LOW	Under lower-limit signal (output, negative logic)
3	/BIN1	Discrimination judgment signal 1 (output, negative logic)
4	/BIN2	Discrimination judgment signal 2 (output, negative logic)
5	/BIN3	Discrimination judgment signal 3 (output, negative logic)
6	/HIGH	Over upper-limit signal (output, negative logic)
7	/EOM	Measuring cycle end, data enable signal (output, negative logic)
8	/EXT_TRIG	External trigger signal (input, negative logic, falling edge)
9	DCV	External DC power supply (input)

The slash "/" preceding signal names indicates a negative logic signal.

Pin Positions

Figure 1 shows the connector pin positions. The connector shell is at the common potential with the instrument chassis.

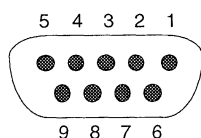

17DE-13090-C (made by Daiichi Denshi Kogyo) or equivalent
(9-pin D-sub connector)

Figure 1. Pin Positions

Internal I/O Equivalent Circuit

• **Input Circuit**

The input circuit varies in optional specifications as shown in Figures 2 and 3.

• **Operation using an external power supply (option /H1)**

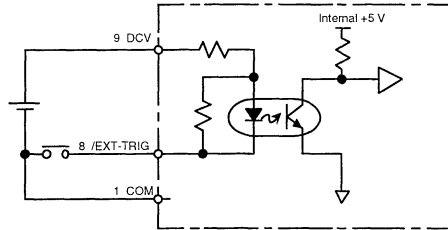

Figure 2. Equivalent Input Circuit for Operation with an External Power Supply

• **Operation using an internal power supply (option /H2)**

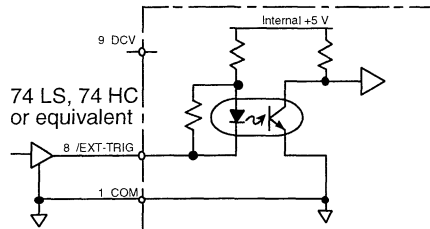

Figure 3. Equivalent Input Circuit for Operation with an Internal Power Supply

Note

As the COM terminal is used in common for operation with an internal power supply (/H1, optional), the input circuit cannot be isolated from the external equipment.

• **Output Circuit (common to both optional specifications /H1 and /H2)**

The output equivalent circuit is shown in Figure 4.

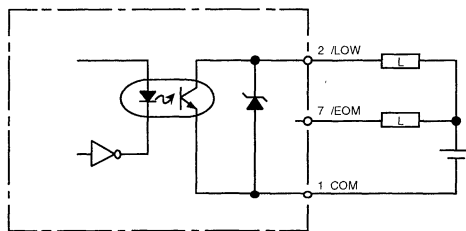

Figure 4. Equivalent Output Circuit

Note

As the COM terminal is used in common for operation with an internal power supply (/H2, optional), the output circuit cannot be isolated from the external equipment.

Timing Chart

• **Normal Mode**

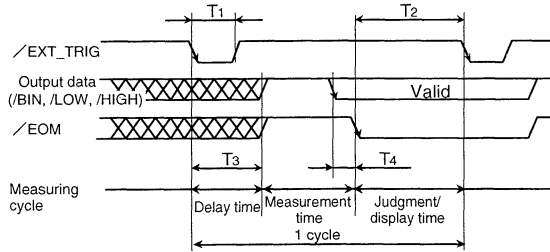

• **Totalization Mode (when SLOPE_A is ↗)**

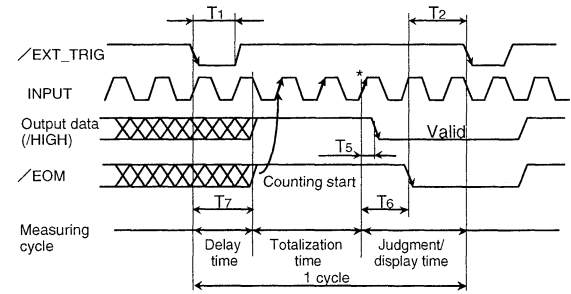

• **Timing Data**

Symbol	Definition	Minimum value	Maximum value	Unit
T1	Width of external trigger pulse	1	—	μs
T2	Trigger waiting time after EOM output	1	—	ms
T3	Delay time for measurement start (normal mode)	100	1000	μs
T4	/EOM delay time (for output data ↓)	1	10	μs
T5	/HIGH output delay time (for input ↑)	—	20	μs
T6	/EOM output delay time (for input ↑)	1	5	ms
T7	Delay time for measurement start (totalization mode)	1	3	ms

Operation Procedure

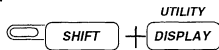

1. Press the **UTILITY (SHIFT + DISPLAY)** key.

Repeat pressing the **SETTING** key until the characters “Set-1” to “Set-4” or “t.out” are displayed.



2. **Numerical value setting**

- Press the **GATETIME/MULTIPLIER** key. (The numerical value is indicated in the display.)
- Set the numerical value by having the digit to be set flash using the **FUNCTION** key and then with the **SETTING** key. For details, see Section 5.6, “Utility,” (page 5-10) in the user’s manual for the counter.

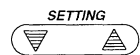

3. **Set the handler operation to ON.**

- Press the **GATETIME/MULTIPLIER** key.
- Repeat pressing the **SETTING** key until the characters “hdL oFF” are displayed.
- Press the **GATETIME/MULTIPLIER** key to display “hdL on.”

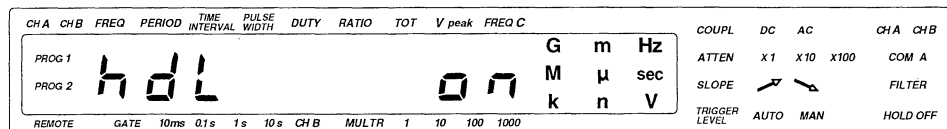
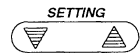

Chapter 6

USING THE COMMUNICATION FUNCTION (GP-IB)

6.1	Outline of Communication Function	6-2
6.2	Communication Function Specifications	6-3
6.3	Response to Interface Messages and Operation in Remote/Local Transfer	6-4
6.4	Status Byte Format	6-5
6.5	Address/Address Mode Setting	6-6
6.6	Measured Data Output	6-7
6.7	Notice Prior to Programming... ..	6-8
6.8	Commands	6-9
6.9	Sample Program for NEC PC-9801 Series Computer	6-22
6.10	Sample Program for IBM PC/AT Computer	6-26

6.1 Outline of Communication Function

Listener Function

The listener function with the GP-IB interface is as follows:

- The same setting as that through key operation on the front panel is available.
- The output instruction for settings and error numbers can be received.

Talker Function

The talker function with the GP-IB interface is as follows:

- Settings can be output.
- Generated error numbers can be output.
- Measurement data can be output.

Note

There is no listen-only function.

6.2 Communication Function Specifications

GP-IB Interface Specifications

- Electrical and mechanical specifications : Conform to IEEE Standard 488-1978
- Functional specifications : See the table below.
- Code used : ISO (ASCII) code
- Address setting : The 0 to 30 talker/listener/addresses or talk-only functions can be set through key operation on the front panel.
- Remote status release : Released by pressing the **LOCAL** key on the front panel. However, the key is not effective if the controller locally locks out the status.

Mechanical Specifications

Function	Subset Name	Description
Source handshake	SH1	This has all the functions of transmitting handshakes.
Acceptor handshake	AH1	This has all the functions of receiving handshakes.
Talker	T5	This has the basic talker and serial polling functions and the talker release function by means of "My Listen Address" (MLA). There is also a talk-only function.
Listener	L4	This has the basic listener function and the listener-release function by means of "My Talker Address" (MTA). There is no listen-only function.
Service request	SR1	This has all the service request functions.
Remote/local	RL1	This has all the remote/local functions.
Parallel polling	PP0	There is no parallel polling function.
Device clear	DC1	This has all the device clear functions.
Device trigger	DT1	This has all the device trigger functions.
Controller	C0	There is no controller function.

6.3 Response to Interface Messages and Operation in Remote/Local Transfer

Response to Interface Message

- **Interface Clear (IFC)**
Releases talker and listener.
- **Remote Enable (REN)**
Moves to the remote state.
- **Go To Local (GTL)**
Moves to the local state.
- **Selective Device Clear (SDC), Device Clear (DCL)**
Clears the GP-IB input/output buffer and resets the error condition. Gives no influence to the settings or measurement conditions.
DCL clears all devices on the bus while **SDC** clears only specified devices.
- **Group Execute Trigger (GET)**
Provides the same operation as the **START** key and **"STAR"** command.
- **Local Lockout (LLO)**
Makes the **LOCAL** key on the front panel inoperable and prohibits transfer to a local state.

Operation in Remote/Local Transfer

- **Local-to-remote transfer**
"REMOTE" is lit on the display. Key operations on the front panel are disabled except for the **LOCAL** key. Settings in the local state are retained even in the remote state.
- **Remote-to-local transfer**
"REMOTE" goes out on the display. Key operations on the front panel are enabled. Settings in the remote state are retained even in the local state.
- **Valid keys in the remote state**
Pressing the **LOCAL** key on the front panel in the remote state transfers to the local state. However, this is invalid if the local lockout state is provided by the controller.

6.4 Status Byte Format

Status Byte Format

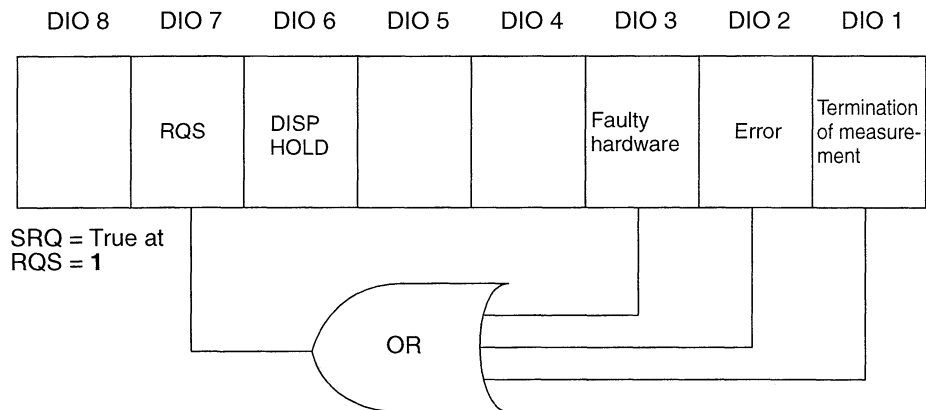

- **RQS (DIO 7)**

RQS becomes **1** when measurement is completed, an error occurs, or hardware is faulty.

When RQS equals **1**, a service request is generated to the controller with SRQ as true. It is reset to **0** after responding to serial polling. When the causes for the termination of measurement, an error occurring, or hardware being faulty is not to be reflected in the status byte, mask that bit with the **MASK** command.

For example,

By indicating "MASK 255," a fault in the hardware, an error, or the termination of measurement is reflected to RQS.

By indicating "MASK 249," only the termination of measurement is reflected to RQS.

By indicating "MASK 250," only the occurrence of an error is reflected to RQS.

- **DISP HOLD (DIO 6)**

The state to hold the display is expressed. This bit becomes **1** in the hold state. RQS is not affected.

- **Faulty Hardware**

When hardware fails during operation (such as the fan stopping), it is set at **1**. It is reset to **0** after it responds to serial polling.

- **Error (DIO 2)**

Error becomes **1** when a command error, execution error, or measurement error occurs. The error number in this case can be inquired using the **ERR?** command. It is reset to **0** after it responds to the serial polling.

- **Termination of Measurement (DIO 1)**

This becomes **1** when the display is updated after one measurement is terminated. For the **BLOC** command, it becomes **1** when measurements of the specified times are terminated. It is reset to **0** after responding to serial polling.

6.5 Address/Address Mode Setting

Before Starting

- **Address Setting**

Each unit connected with the GP-IB interface has a specific address in the GP-IB system and is identified by this address. Accordingly, it is necessary to set the address of the TC100 series counter.

Also, if the counter is connected to a listen-only device on a 1:1 basis, set the address of the TC100 series counter to talk-only.

- **Address setting range**

0 to 30

Set at 1 upon shipment from the factory.

In addition, the set address is retained even when the settings are initialized.

- **Terminator**

- When the TC100 series counter is a listener:

The receiving terminator can be received by either **CR+LF**, **LF**, or **EOI**.

- When the TC100 series counter is a talker:

The sending terminator is set with the **TERM** command. The terminator is **CR+LF** when the power is on.

- **Talk-only function**

This is a function of only transmitting data to other devices always in the talker state. It can transmit data without being specified as the talker. It is not controlled by the controller.

Note

When the terminator transmitted from the controller includes only CR, it cannot be received by the TC100 series counter. In addition, it cannot use CR for the terminator to be transmitted from the TC100 series counter.

Operation Procedure

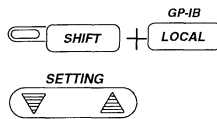

1. Press the GP-IB (SHIFT+LOCAL) key.

2. Change the address by pressing the SETTING key.

The address changes as shown below.

“t.only” → “Adrs. 0” → “Adrs. 1” → ... → “Adrs. 30”

For talk-only, set the address to “t.only.”

Note

If the address setting is to be aborted, press any key other than the SETTING key.

6.6 Measured Data Output

Discrimination of Measured Data Output from Return Data for Inquiring Command

The TC100 series counter is always outputting measured data. However, if data are requested after sending an inquiry (e.g., "TRIG?"), a return data item corresponding to the inquiry is output.

Measured Data Output Timing

- The TC100 series counter, if requested for data by the controller, outputs data after measurement is completed, updating the display at the same time.
- If the duration when the controller receives a measurement is smaller than the display updating period, the measurement or the displayed data can all be received through the GP-IB interface.
- If the duration when the controller receives a measurement is longer than the display updating period, the measurement at the time when the controller receives the data is received.
- If measured data are read in, it is recommended that "STAR" be sent once the first time. This resets measurement and data measured after resetting are sent to the GP-IB system subsequently. Without resetting, previously measured data may be read.

Measured Data Output Format

1. Frequency, period, time interval, pulse width, and number of revolutions

D ₁	D ₂	D ₃	D ₄	D ₅	D ₆	D ₇	D ₈	D ₉	D ₁₀	U ₁	U ₂	U ₃	CR	LF	.EOI*
----------------	----------------	----------------	----------------	----------------	----------------	----------------	----------------	----------------	-----------------	----------------	----------------	----------------	----	----	-------

D ₁	D ₂	D ₃	D ₄	D ₅	D ₆	D ₇	D ₈	D ₉	D ₁₀	U ₁	U ₂	U ₃	LF	.EOI*
----------------	----------------	----------------	----------------	----------------	----------------	----------------	----------------	----------------	-----------------	----------------	----------------	----------------	----	-------

* At the last byte transfer EOI = TRUE

2. Duty ratio, frequency ratio, totalized counting (however, if the scaling function is used, the same as described in 1 above)

D ₁	D ₂	D ₃	D ₄	D ₅	D ₆	D ₇	D ₈	D ₉	D ₁₀	CR	LF	.EOI*
----------------	----------------	----------------	----------------	----------------	----------------	----------------	----------------	----------------	-----------------	----	----	-------

D ₁	D ₂	D ₃	D ₄	D ₅	D ₆	D ₇	D ₈	D ₉	D ₁₀	LF	.EOI*
----------------	----------------	----------------	----------------	----------------	----------------	----------------	----------------	----------------	-----------------	----	-------

* At the last byte transfer EOI = TRUE

3. Peak voltage

D ₁	D ₂	D ₃	D ₄	D ₅	,	D ₆	D ₇	D ₈	D ₉	D ₁₀	CR	LF	.EOI*
----------------	----------------	----------------	----------------	----------------	---	----------------	----------------	----------------	----------------	-----------------	----	----	-------

D ₁	D ₂	D ₃	D ₄	D ₅	,	D ₆	D ₇	D ₈	D ₉	D ₁₀	LF	.EOI*
Minimum voltage					Maximum voltage							

* At the last byte transfer EOI = TRUE

D1 to D10 Numeric value data (right-justified, space is ASCII code 20H)

U1 to U3 Unit (left-justified, space is ASCII code 20H)
 Unit symbol for "HEAD ON" (e.g., **MHz**)
 For "HEAD OFF," expression in Hz or s in powers of 10 (e.g., **E+9**)

6.8 Commands

The following table shows all the commands for the TC100 series counter described on the following pages. Either type 0 or type 1 commands can be used.

Contents	Type 0	Type 1	Page
Measurement function setting Measurement function inquiry	FUNC FUNC?	F	6-11
Gate-time setting Gate-time inquiry	GATE GATE?	G	6-12
Multiplier setting Multiplier inquiry	MULT MULT?	G	6-12
Setting for setting channel Inquiry for setting channel	CHAN CHAN?		6-13
Slope setting Slope inquiry	SLOP SLOP?		6-13
Coupling setting Coupling inquiry	COUP COUP?		6-13
Attenuator setting Attenuator inquiry	ATT ATT?		6-14
Filter setting Filter inquiry	FILT FILT?		6-14
Common-input setting Common-input inquiry	COMA COMA?		6-14
Trigger mode level setting Trigger mode level inquiry	TRIG TRIG?		6-15
Hold-off time setting Hold-off time inquiry	HOFF HOFF?		6-15
Display contents setting Display contents inquiry	DISP DISP?		6-15
Display-hold setting Display-hold setting inquiry	DHOL DHOL?	S	6-16
Measurement start	STAR	E	6-16
Program designation Program inquiry	PROG PROG?		6-16
Setting of scaling/offset of program 1 Inquiry of scaling/offset of program 1	PRG1 PRG1?		6-17
Setting of scaling/offset of program 2 Inquiry of scaling/offset of program 2	PRG2 PRG2?		6-17
Initialization of settings	INIT	C	6-17
Storage of settings	STOR		6-17
Recall of settings	REC		6-18
Header on/off	HEAD		6-18
Status byte masking setting Status byte masking inquiry	MASK MASK?	S	6-18
Error number inquiry	ERR?		6-18
Display digit masking setting Display digit masking inquiry	CUT CUT?		6-19
Reference signal inquiry	REF?		6-19
Transmitting terminator setting Transmitting terminator inquiry	TERM TERM?	DL	6-19
Model inquiry	IDEN?		6-19
Option inquiry	OPT?		6-20
Block measurement to sample memory	BLOC		6-20
D/A output on/off setting D/A output on/off inquiry	DOUT DOUT?		6-20
D/A output Low and High setting D/A output Low and High inquiry	DSET DSET?		6-21
Handler interface on/off setting Handler interface on/off inquiry	HAND HAND?		6-22
Handler interface delimiting value settings Handler interface delimiting value inquiry	SET1 to 4 SET1? to SET4?		6-22
Handler interface time out setting Handler interface time out inquiry	TOUT TOUT?		6-23
Result of delimitation inquiry	BIN?		6-23

Explanation Before Reading Pages 6-11 to 6-21.

An explanation on reading the details for the commands described on pages 6-11 to 6-21 are given below.

- **Command type**

Type 0 commands are representative of commands. If a type 1 command for the same action exists, their difference is distinguished by using (type 0) or (type 1). If this distinction is not made, then that command is type 0. Note carefully that the parameters and others vary with the type.

- **Inquiries**

Commands that have a ? at the end are inquiries. Return data for this command are expressed as shown below.

Example `FILT?` → $\left\{ \begin{array}{l} \text{FILT} \quad \left\{ \begin{array}{l} \text{OFF} \\ \text{ON} \end{array} \right\} \quad (\text{for HEAD ON}) \\ \left\{ \begin{array}{l} \text{OFF} \\ \text{ON} \end{array} \right\} \quad (\text{for HEAD OFF}) \end{array} \right.$

Return data differ between header being on and off. Header on/off is set with the **HEAD command** (see page 6-18). This is set at HEAD ON when the power is turned on. In addition, commands which have special return data format (such as "IDEN?") are specifically noted.

- **Numeric parameters**

Enter HI and Lo values for scaling/offset and D/A output as shown below.

Example In the case of
 High value = * *. * * or * *. * *E±*
 Unit = mHz/Hz/kHz/MHz/GHz

Set them as 123.45 kHz or 123.45E+3.

The number of asterisks above has no relation to the result. Digits below those for the settable resolution are rounded down. For setting range and resolution, refer to the pages or specifications describing the operation. When entering a unit, be sure to distinguish between upper-case and lower-case letters.

FUNC/FUNC?

Sets or inquires about measurement functions.

(type 0)

FUNC **<Function>** **FUNC?**

<Function> = FRQA : Frequency A
FRQB : Frequency B
FRQC : Frequency C (only for the TC120)
PERI : Period B
TINT : Time interval A → B
PWID : Pulse width B
DUTY : Duty ratio B
RATI : Frequency ratio A/B
TOT : Totalized counting A
VPKA : Peak voltage A
VPKB : Peak voltage B
RPM : Number of revolutions (only for the TC110)

(type 1)

F<Numeric value>

<Numeric value> = 1: Frequency A
2: Frequency B
3: Frequency C (only for the TC120)
4: Period B
5: Time interval A → B
6: Frequency ratio A/B
7: Totalized counting (DISP HOLD ON)
8: Totalized counting (DISP HOLD OFF)

GATE/GATE?

Sets or inquires about the gate time. This command is valid if the measurement function is frequency, totalized counting or number of revolutions.

(type 0)

```
GATE <Gate time>          GATE?
      <Gate time> = 10 ms
                    0.1 s
                    1 s
                    10 s
                    CHB
                    OFF
```

(type 1)

G <Numeric value>

```
<Numeric value> = 0: 10 ms
                  1: 0.1 s
                  2: 1 s
                  3: 10 s
                  4: CHB
```

- The gate-time setting GATE CHB is valid only when the measurement function is frequency A or totalized counting. The gate-time setting GATE OFF is used for releasing GATE CHB with the measurement function set to the totalized function.

MULT/MULT?

Sets or inquires about the multiplier. This command is valid when the measurement function is period, time interval, pulse width, duty ratio, or frequency ratio.

(type 0)

```
MULT <Multiplier>          MULT?
      <Multiplier> = 1
                    10
                    100
                    1000
```

(type 1)

G <Numeric value>

```
<Numeric value> = 0: 1
                  1: 10
                  2: 100
                  3: 1000
```

CHAN/CHAN?

Selects or inquires about the channel to which the input conditions are to be set.

(type 0)

CHAN $\left\{ \begin{array}{c} A \\ B \\ C \end{array} \right\}$ CHAN?

- A channel currently having nothing for measurement cannot be selected. Set the input conditions after setting the measurement function and gate time.

SLOP/SLOP?

Sets or inquires about the slope of the currently set channel.

(type 0)

SLOP $\left\{ \begin{array}{c} POS \\ NEG \end{array} \right\}$ SLOP?

- If the measurement function is set to frequency A or frequency C, the slope setting is fixed to SLOP POS. Note carefully that the slope setting cannot be changed.

COUP/COUP?

Sets or inquires about the coupling of the currently set channel.

(type 0)

COUP $\left\{ \begin{array}{c} AC \\ DC \end{array} \right\}$ COUP?

- If the measurement function is set to frequency C, the coupling setting is fixed to COUP AC. Note carefully that the coupling setting cannot be changed.

ATT/ATT?

Sets or inquires about the attenuator for the currently set channel.

(type 0)

ATT <Attenuator>

ATT?

<Attenuator> = 1
 10
 100

- If the measurement function is set to frequency C, the attenuator setting is fixed to ATT1. Note carefully that the attenuator setting cannot be changed.

FILT/FILT?

Sets or inquires about the filter for the currently set channel.

(type 0)

FILT { ON
 OFF }

FILT?

- If the measurement function is set to peak voltage or frequency C, the filter setting is fixed to FILT OFF. Note carefully that the filter setting cannot be changed.

COMA/COMA?

Sets or inquires about a common input.

(type 0)

COMA { ON
 OFF }

COMA?

- If the measurement function is set to frequency C, the common input setting is fixed to COMA OFF. Note carefully that the common input setting cannot be changed.

TRIG/TRIG?

Sets or inquires about the trigger mode/trigger level for the currently set channel.

(type 0)

TRIG AUTO TRIG?
 <Trigger level>

<Trigger level> = -5.00 V to 5.00 V (0.02V-steps, for ATTEN × 1)
 -50.0 V to 50.0 V (0.2V-steps, for ATTEN × 10)
 -250 V to 250 V (2 V-steps, for ATTEN × 100)

- If the measurement function is set to frequency C, the trigger mode/trigger level setting is fixed to TRIG AUTO. Note carefully that the trigger mode/trigger level setting cannot be changed.

HOFF/HOFF?

Sets or inquires about the hold-off time.

(type 0)

HOFF OFF HOFF?
 <Hold-off time>

<Hold-off time> = 100 μs, 200 μs, 300 μs, 400 μs, 500 μs, 600 μs, 700 μs,
 800 μs, 900 μs, 1 ms, 2 ms, 3 ms, 4 ms, 5 ms, 6 ms,
 7 ms, 8 ms, 9 ms, 10 ms, 20 ms, 30 ms, 40 ms, 50 ms,
 60 ms, 70 ms, 80 ms, 90 ms, or 100 ms

- The hold-off time can be set only when the measurement function is set to frequency B, period, time interval, pulse width, duty ratio, totalized counting, or the number of revolutions.

DISP/DISP?

Sets or inquires about the display.

(type 0)

DISP <Display contents> DISP?

<Display contents> = MEAS : Measured value indication
 TRIG : Trigger level indication
 HOFF : Hold-off time indication
 BIN : BIN judgment result indication
 (only when the handler is ON)

DHOL/DHOL?

Sets or inquires about display holding.

(type 0)

DHOL $\left\{ \begin{array}{c} \text{ON} \\ \text{OFF} \end{array} \right\}$ DHOL?

(type 1)

S3: ON

S2: OFF

- If DHOL ON is set, display updating is held. If DHOL OFF is set, holding is released and the display is updated continually.
- If a STAR command is sent with DHOL ON set, measurement is made once and then stopped. If a "STAR" command is set with "DHOL OFF" set, measurement is reset and again started.

STAR

Resets and starts measurement.

(type 0)

STAR

(type 1)

E

PROG/PROG?

Specifies or inquires about a program.

(type 0)

PROG $\left\{ \begin{array}{c} \text{OFF} \\ 1 \\ 2 \end{array} \right\}$ PROG?

- If the measurement function is set to peak voltage, the program setting is fixed to PROG OFF. Note carefully that the program setting cannot be changed.

PRG1/PRG1?

Sets or inquires about the scale and offset of program 1.

(type 0)

PRG1 <Scale>, <Offset>

PROG1?

<Scale> = ***.***

-999.999 to 999.999

<Offset> = ***.**E±*

-999.999E+6 to 999.999E+6 (for the TC110)

-999.999E+9 to 999.999E+9 (for the TC120)

PRG2/PRG2?

Sets or inquires about the scale and offset of program 2.

(type 0)

PRG2 <Scale>, <Offset>

PROG2?

<Scale> = ***.***

-999.999 to 999.999

<Offset> = ***.**E±*

-999.999E+6 to 999.999E+6 (for the TC110)

-999.999E+9 to 999.999E+9 (for the TC120)

INIT

Initializes settings. However, the settings stored by setting the GP-IB and STOR are not initialized.

(type 0)

INIT

(type 1)

C

STOR

Stores the current settings in memory.

(type 0)

STOR<Number>

<Number> = 1 to 8

REC

Recalls the settings stored in memory.

(type 0)

REC <Number>

<Number> = 1 to 8

HEAD

Sets the header of return data on/off. If the header is set to on, a command is added to the return data while if it is set to off, the return data are only the parameter. When the power is turned on, HEAD ON is set.

(type 0)

HEAD { ON
OFF }

MASK/MASK?

Sets or inquires about the mask of a status byte. For only the bits of a masking pattern set to 1, the status byte is valid. When the power is turned on, the status byte is set to MASK 255.

(type 0)

MASK <Numeric value> MASK?

<Numeric value> = 0 to 255

(type 1)

S0: MASK 255

S1: MASK 0

ERR?

Inquires about an error number generated. Once inquired about, the error is reset. If there is no error, "0" is output.

(type 0)

ERR?

CUT/CUT?

Sets or inquires about display digit masking.

(type 0)

CUT <Number of digits> CUT?

<Number of digits> = 0 to 9

REF?

Inquires whether the reference signal is internal or external.

(type 0)

REF?

INT: Internal reference signal

EXT: External reference signal

TERM/TERM?

Sets and inquires about the transmitting terminator (terminator in return). When the power is turned on, the terminator is set to TERM CRLF.

(type 0)

TERM { CRLF }
 { LF }

(type 1)

DL 0: CRLF

DL 1: LF

IDEN?

Inquires about the model of the TC100 series counter.

(type 0)

IDEN?

YOKOGAWA, <Model>, 0, 0

<Model> = 704111: TC110

704112: TC120

OPT?

Inquires whether an optional function is present or not.

(type 0)
OPT?

NO: No optional function
/D1: Optional function of D/A output

BLOC

Makes block measurements for sample memories. Transmits measured data for the specified number of samples when measurement is completed.

(type 0)
BLOC <Number of samples>, <Sample interval>

<Number of samples> = 1 to 1024
<Sample interval> = 10 ms to 300 s

- The format of measured data to be transmitted is the same as the output format for normal measured data (see page 6-7). However, in the case of HEAD ON, the following time data are added before the measured data output format. (Time data are not added in the case of HEAD OFF.)

T ₁	T ₂	T ₃	T ₄	T ₅	T ₆	T ₇	T ₈	T ₉	T ₁₀	,
----------------	----------------	----------------	----------------	----------------	----------------	----------------	----------------	----------------	-----------------	---

+ Measured data output format

T₁ to T₁₀ : Time data (Integer in 1-μs steps, right justified, space in ASCII code 20H)
Unit of measured data : Always expressed in powers of ten.

- If <sample interval> is omitted or is 0 s, the data are sampled as fast as possible.
- For use of this command, see sample program 4.
- This command cannot be used for the measurement function of duty ratio measurement, totalized counting, or peak voltage measurement.

DOUT/DOUT?

Sets or inquires about turning on/off D/A output.

(type 0)
DOUT { ON } DOUT?
 { OFF }

- This command is only used for models with the D/A output option.

DSET/DSET?

Sets or inquires about Low and High values in D/A output.

(type 0)

DSET <Low value><Unit>, <High value><Unit> DSET?

<Low value>

<High value> = ***.** or ***.**E±*

<Unit> = mHz/Hz/kHz/MHz/GHz (for measurement function of frequency)

ns/μs/ms/s (for measurement function of period, time interval, or pulse width)

mrp/rp/krp/Mrp (for measurement function of number of revolutions)

Dimensionless (for measurement of duty ratio or frequency ratio)

- Return for inquiries:
In the case of HEAD ON, return is made with units. → Ex. 123.45 kHz
In the case of HEAD OFF, return is made without units. → Ex. 123.45E+3
- This command can be used only for models with the D/A output option.

- The following commands are only to be used for models with the handler interface option (/H1, /H2).

HAND/HAND?

Sets or inquires handler operation ON/OFF.

(type 0)

HAND $\left\{ \begin{array}{c} \text{ON} \\ \text{OFF} \end{array} \right\}$ HAND?

SET1/SET1?

Sets or inquires SET1 (delimiting value 1).

(type 0)

SET1 <Value><Unit> SET1?

<Value> = *****.** or ***.**E ± ***

<Unit> = **mHz/Hz/kHz/MHz/GHz (for frequency)**
ns/us/ms/s (for period, time interval, or pulse width)
mrp/rp/krp/Mrp (for revolutions)
Dimensionless (for duty ratio or frequency ratio)

SET2/SET2?

Sets or inquires SET2 (delimiting value 2).

- The setting and inquiry methods are the same as for SET1. See above.

SET3/SET3?

Sets or inquires SET3 (delimiting value 3).

- The setting and inquiry methods are the same as for SET1. See above.

SET4/SET4?

Sets or inquires SET4 (delimiting value 4).

- The setting and inquiry methods are the same as for SET1. See above.

TOUT/TOUT?

Sets or inquires handler interface time out.

(type 0)

TOUT OFF TOUT?
 <Timeout time>

<Timeout time> = 10 ms, 20 ms, 50 ms, 100 ms, 200 ms, 500 ms, 1 s, 2 s,
 5 s, 10 s, 20 s, 50 s, 100 s, and 200 s

BIN?

Inquires the results of delimitation.

(type 0)

BIN?

NO	Measurement not completed
LOW, BIN1, BIN2, BIN3, HIGH	Results of delimitation when successfully exited
TIMEOUT	Timeout

6.9 Sample Program for NEC PC-9801 Series Computer

• Sample Program 1

```
1000 '*****
1010 '*
1020 '* TC110/120 Sample Program 1 PC98 N88 BASIC
1030 '*
1040 '*
1050 '******
1060 '*
1070 '* Set the TC110/120 as shown below.
1080 '*
1090 '* Measurement function Time interval
1100 '* Multiplier 100
1110 '*
1120 '* Channel A setting
1130 '* Slope Rise
1140 '* Coupling DC
1150 '* Attenuator x 1
1160 '* Filter OFF
1170 '* Trigger level 2.5 V
1180 '*
1190 '* Channel B setting
1200 '* Slope Fall
1210 '* Coupling DC
1220 '* Attenuator x 1
1230 '* Filter OFF
1240 '* Trigger level 2.5 V
1250 '*
1260 '* Hold-off OFF
1270 '* Common input OFF
1280 '*
1290 '*****
1300 '
1310 ADRS = 1 ' Set the GP-IB address to a variable ADRS
1320 '
1330 ISET IFC ' Interface clear
1340 ISET REN ' Set the interface to remote.
1350 '
1360 PRINT @ADRS;"INIT" ' Initialize setting.
1370 '
1380 PRINT @ADRS;"FUNC TINT" ' Set the function to the time interval.
1390 PRINT @ADRS;"MULT 100" ' Set the multiplier to 100.
1400 '
1410 PRINT @ADRS;"CHAN A" ' Select channel A.
1420 PRINT @ADRS;"SLOP POS" ' Set the slope to rise.
1430 PRINT @ADRS;"COUP DC" ' Set the coupling to DC.
1440 PRINT @ADRS;"ATT 1" ' Set the attenuator to x1.
1450 PRINT @ADRS;"FILT OFF" ' Set the filter to off.
1460 PRINT @ADRS;"TRIG 2.5V" ' Set the trigger level to 2.5 V.
1470 '
1480 PRINT @ADRS;"CHAN B" ' Select channel B.
1490 PRINT @ADRS;"SLOP NEG" ' Set the slope to fall.
1500 PRINT @ADRS;"COUP DC" ' Set the coupling to DC.
```

```

1510 PRINT @ADRS;"ATT 1"           ' Set the attenuator to X1.
1520 PRINT @ADRS;"FILT OFF"       ' Set the filter to off.
1530 PRINT @ADRS;"TRIG 2.5V"     ' Set the trigger level to 2.5 V.
1540 '
1550 PRINT @ADRS;"HOFF OFF"      ' Set the hold-off to off.
1560 PRINT @ADRS;"COMA OFF"      ' Set the common input to off.
1570 '
1580 END                           ' End

```

• Sample Program 2

```

1000 '*****
1010 '*                               *
1020 '*   TC110/120 Sample Program 3  PC98  N88 BASIC                       *
1030 '*                                     & NEC Genuine GP-IB Board       *
1040 '*                               *
1050 '*****
1060 '*                               *
1070 '*   Measurement remains on the display until any key is pressed.     *
1080 '*                               *
1090 '*****
1100 '
1110 ADRS = 1                        ' Set the GP-IB address to a variable ADRS.
1120 '
1130 ISET IFC                        ' Interface clear
1140 ISET REN                        ' Set the interface to remote.
1150 '
1160 PRINT @ADRS;"DHOL OFF"         ' Release display holding.
1170 '
1180 PRINT @ADRS;"STAR"             ' Measurement starts and the transmitting
                                     ' buffer clears
1190 '
1200 WHILE(INKEY$=" ")              ' Loop until any key is pressed.
1210 '
1220   LINE INPUT @ADRS;DAT$        ' Read in the measurement to the character
                                     ' variable DAT$.
1230   PRINT DAT$                   ' Measurement is displayed.
1240 '
1250 WEND                            ' Loop end
1260 '
1270 END                              ' End

```

• Sample Program 3

```
1000 '*****
1010 '*
1020 '* TC110/120 Sample Program 3 PC98 N88 BASIC
1030 '* & NEC Genuine GP-IB Board
1040 '*
1050 '*****
1060 '* When any key is pressed, measurement is made once and the
1070 '* result is indicated on the display.
1080 '* When the ESC key is pressed, the program ends.
1090 '*
1100 '*****
1110 '
1120 ADRS = 1 ' Set the GP-IB address to a variable ADRS.
1130 '
1140 ISET IFC ' Interface clear
1150 ISET REN ' Set the interface to remote.
1160 '
1170 PRINT @ADRS;"DHOL ON" ' Display holds
1180 '
1190 WHILE(1) ' Infinite loop
1200 '
1210 K$ = INPUT$(1) ' Waiting for key entry.
1220 IF K$=CHR$(27) THEN *EXIT ' If the ESC key is pressed, exit from the
' infinite loop.
1230 PRINT @ADRS;"STAR" ' Measurement starts and the transmitting
' buffer clears.
1240 LINE INPUT @1;DAT$ ' Read in the measurement to the character
' variable DAT$.
1250 PRINT DAT$ ' Measurements are displayed.
1260 '
1270 WEND ' Loop end
1280 '
1290 *EXIT : END ' End
```

• Sample Program 4

```

1000 '*****
1010 '*
1020 '* TC110/120 Sample Program 4 PC98 N88 BASIC
1030 '*
1040 '*
1050 '*****
1060 '*
1070 '* Sample 500 data items at high speed using the BLOC command
1080 '* and display them together with the time data.
1090 '*
1100 '* By using this command, a maximum of 1024 data items can be
1110 '* stored in memory at high speed with the time data.
1120 '* The stored data can be fetched by reading the data
1130 '* subsequently.
1140 '*
1150 '* If this command is used, the measurement-completion bit of the
1160 '* status byte (BIT0) changes to 1 when measurement of the
1170 '* specified number of data is completed.
1180 '*****
1190 '
1200 DIM DAT$(500) ' Ensure an array of 500 character
variables.
1210 '
1220 ADRS = 1 ' Set the GP-IB address to a variable ADRS.
1230 '
1240 ISET IFC ' Interface clear
1250 ISET REN ' Set the interface to remote.
1260 '
1270 PRINT @ADRS;"HEAD ON" ' Specify together with the time data.
1280 '
1290 PRINT @ADRS;"DHOL ON" ' Display holds.
1300 '
1310 PRINT @ADRS;"BLOC 500" ' Sample 500 data items at high speed.
1320 '
1330 FOR I=1 TO 500 ' Loops 500 times
1340 '
1350 LINE INPUT @ADRS;DAT$(I) ' Read in measurements to the character
' variable DAT$.
1360 PRINT DAT$(I) ' Display the measurement.
1370 '
1380 NEXT ' Loop end
1390 '
1400 END ' End

```

6.10 Sample Program for IBM PC/AT Computer

• Sample Program 1

```
1000 '*****
1010 '*
1020 '* TC110/120 Sample Program 1 IBM-PC BASIC A
1030 '*
1040 '*
1050 '*****
1060 '*
1070 '* Set the TC110/120 as shown below.
1080 '*
1090 '* Measurement function Time interval
1100 '* Multiplier 100
1110 '*
1120 '* Channel A setting
1130 '* Slope Rise
1140 '* Coupling DC
1150 '* Attenuator x 1
1160 '* Filter OFF
1170 '* Trigger level 2.5 V
1180 '*
1190 '* Channel B setting
1200 '* Slope Fall
1210 '* Coupling DC
1220 '* Attenuator x 1
1230 '* Filter OFF
1240 '* Trigger level 2.5 V
1250 '*
1260 '* Hold-off OFF
1270 '* Common input OFF
1280 '*
1290 '*****
1300 'GP-IB declaration
1310 '
1320 CLEAR ,50000!
1330 IBINIT1 = 50000!
1340 IBINIT2 = IBINIT1 + 3
1350 BLOAD "bib.m",IBINIT1
1360 CALL IBINIT1(IBFIND,IBTRG,IBCLR,IBPCT,IBSIC,IBLOC,IBPPC,IBBNA,IBONL,
IBRSC,IBSRE,IBRSV,IBPAD,IBSAD,IBIST,IBDMA,IBEOS,IBTMO,IBEOT,IBRDF,
IBWRTF)
1370 CALL IBINIT2(IBGTS,IBCAC,IBWAIT,IBPOKE,IBWRT,IBWRTA,IBCMD,IBCMDA,
IBRD,IBRDA,IBSTOP,IBRPP,IBRSP,IBDIAG,IBXTRC,IBRDI,IBWRTI,IBRDIA,
IBWRTIA,IBSTA%,IBERR%,IBCNT%)
1380 '
1390 DEVICE$ = "TC100" : CALL IBFIND(DEVICE$,TC%) ' Device open
1400 CALL IBSIC(TC%) ' Interface clear
1410 '
1420 CMD$ = "INIT" : CALL IBWRT(TC%,CMD$) ' Initialize setting.
1430 '
1440 CMD$ = "FUNC TINT" : CALL IBWRT(TC%,CMD$) ' Set the function to the time
' interval.
1450 CMD$ = "MULT 100" : CALL IBWRT(TC%,CMD$) ' Set the multiplier to 100.
1460 '
1470 CMD$ = "CHAN A" : CALL IBWRT(TC%,CMD$) ' Select channel A.
1480 CMD$ = "SLOP POS" : CALL IBWRT(TC%,CMD$) ' Set the slope to rise.
1490 CMD$ = "COUP DC" : CALL IBWRT(TC%,CMD$) ' Set the coupling to DC.
1500 CMD$ = "ATT 1" : CALL IBWRT(TC%,CMD$) ' Set the attenuator to x1.
```

```

1510 CMD$ = "FILT OFF"      : CALL IBWRT(TC%,CMD$) ' Set the filter to off.
1520 CMD$ = "TRIG 2.5V"    : CALL IBWRT(TC%,CMD$) ' Set the trigger level to 2.5 V.
1530 '
1540 CMD$ = "CHAN B"       : CALL IBWRT(TC%,CMD$) ' Select channel B.
1550 CMD$ = "SLOP NEG"     : CALL IBWRT(TC%,CMD$) ' Set the slope to fall.
1560 CMD$ = "COUP DC"      : CALL IBWRT(TC%,CMD$) ' Set the coupling to DC.
1570 CMD$ = "ATT 1"        : CALL IBWRT(TC%,CMD$) ' Set the attenuator to x1.
1580 CMD$ = "FILT OFF"     : CALL IBWRT(TC%,CMD$) ' Set the filter to off.
1590 CMD$ = "TRIG 2.5V"    : CALL IBWRT(TC%,CMD$) ' Set the trigger level to 2.5 V.
1600 '
1610 CMD$ = "HOFF OFF"     : CALL IBWRT(TC%,CMD$) ' Set the hold-off to off.
1620 CMD$ = "COMA OFF"     : CALL IBWRT(TC%,CMD$) ' Set the common input to off.
1630 '
1640 END                      ' End

```

• Sample Program 2

```

1000 '*****
1010 '*
1020 '* TC110/120 Sample Program 2 IBM-PC BASIC A
1030 '*
1040 '*
1050 '*****
1060 '*
1070 '* Measurement remains on the display until any key is pressed.
1080 '*
1090 '*****
1100 'GP-IB declaration.
1110 '
1120 CLEAR ,50000!
1130 IBINIT1 = 50000!
1140 IBINIT2 = IBINIT1 + 3
1150 BLOAD "bib.m", IBINIT1
1160 CALL IBINIT1 (IBFIND, IBTRG, IBCLR, IBPCT, IBSIC, IBLOC, IBPPC, IBNA, IBONL,
1170 IBRSC, IBSRE, IBSRV, IBPAD, IBSAD, IBIST, IBDMA, IBEOS, IBTMO, IBEOT, IBRDF,
1180 IBWRTF)
1170 CALL IBINIT2 (IBGTS, IBCAC, IBWAIT, IBPOKE, IBWRT, IBWRTA, IBCMD, IBCMDA,
1180 IBRD, IBRDA, IBSTOP, IBRPP, IBRSP, IBDIAG, IBXTRC, IBRDI, IBWRTI, IBRDIA,
1190 IBWRTIA, IBSTA%, IBERR%, IBCNT%)
1180 '
1190 DEVICE$ = "TC100" : CALL IBFIND (DEVICE$, TC%) ' Device open
1200 CALL IBSIC (TC%) ' Interface clear
1210 '
1220 CMD$ = "DHOL OFF" : CALL IBWRT (TC%, CMD$) ' Release display holding.
1230 '
1240 CMD$ = "STAR" : CALL IBWRT (TC%, CMD$) ' Measurement starts and the
1250 ' transmitting buffer clears
1260 WHILE (INKEY$ = "") ' Loop until any key is pressed.
1270 '
1280 DAT$ = SPACE$ (80) : CALL IBRD (TC%, DAT$) ' Read in the measurement to the
1290 ' character variable DAT$.
1290 DAT$ = LEFT$ (DAT$, IBCNT% - 2) ' Reshape into a character string
1300 ' of up to the number of received
1310 ' characters - 2.
1300 PRINT DAT$ ' Measurement is displayed.
1310 '
1320 WEND ' Loop end

```



```

1330 '
1340 END ' End

```

• Sample Program 3

```

1000 '*****
1010 '*
1020 '* TC110/120 Sample Program 3 IBM-PC BASIC A
1030 '* & NI GPIB-PC
1040 '*
1050 '*****
1060 '*
1070 '* When any key is pressed, measurement is made once and the
1080 '* result is indicated on the display.
1090 '* When the ESC key is pressed, the program ends.
1100 '*****
1110 'GP-IB declaration
1120 '
1130 CLEAR ,50000!
1140 IBINIT1 = 50000!
1150 IBINIT2 = IBINIT1 + 3
1160 BLOAD "bib.m",IBINIT1
1170 CALL IBINIT1 (IBFIND,IBTRG,IBCLR,IBPCT,IBSIC,IBLOC,IBPPC,IBBNA,IBONL,
IBRSC,IBSRE,IBRSV,IBPAD,IBSAD,IBIST,IBDMA,IBEOS,IBTMO,IBEOT,IBRDF,
IBWRTF)
1180 CALL IBINIT2 (IBGTS,IBCAC,IBWAIT,IBPOKE,IBWRT,IBWRTA,IBCMD,IBCMDA,
IBRD,IBRDA,IBSTOP,IBRPP,IBRSP,IBDIAG,IBXTRC,IBRDI,IBWRTI,IBRDIA,
IBWRTIA,IBSTA%,IBERR%,IBCNT%)
1190 '
1200 DEVICE$ = "TC100" : CALL IBFIND (DEVICE$,TC%) ' Device open
1210 CALL IBSIC (TC%) ' Interface clear
1220 '
1230 CMD$ = "DHOL ON" : CALL IBWRT (TC%,CMD$) ' Display holds.
1240 '
1250 WHILE (1) ' Infinite loop
1260 '
1270 K$ = INPUT$(1) ' Waiting for key entry.
1280 IF K$=CHR$(27) THEN 1360 ' If the ESC key is pressed, exit
' from the infinite loop.
1290 CMD$ = "STAR" : CALL IBWRT (TC%,CMD$) ' Measurement starts and the
' transmitting buffer clears.
1300 DAT$ = SPACE$(80) : CALL IBRD (TC%,DAT$) ' Read in the measurement to the
' character variable DAT$.
1310 DAT$ = LEFT$(DAT$,IBCNT%-2) ' Reshape into a character string
' of up to the number of received
' characters - 2.
1320 PRINT DAT$ ' Measurements are displayed.
1330 '
1340 WEND ' Loop end
1350 '
1360 END ' End

```

• Sample Program 4

```

1000 '*****
1010 '*
1020 '* TC110/120 Sample Program 4 IBM-PC BASIC A
1030 '* & NI GPIB-PC

```

```

1040 '*'
1050 '*****'
1060 '*'
1070 '*'      Sample 500 data items at high speed using the BLOC command
1080 '*'      and display them together with the time data.
1090 '*'
1100 '*'      By using this command, a maximum of 1024 data items can be
1110 '*'      stored in memory at high speed with the time data.
1120 '*'      The stored data can be fetched by reading the data
1130 '*'      subsequently.
1140 '*'
1150 '*'      If this command is used, the measurement-completion bit of
1160 '*'      the status byte (BIT0) changes to 1 when measurement of the
1170 '*'      specified number of data is completed.
1180 '*****'
1190 'GP-IB declaration
1200 '
1210   CLEAR      ,50000!
1220   IBINIT1 = 50000!
1230   IBINIT2 = IBINIT1 + 3
1240   BLOAD "bib.m", IBINIT1
1250   CALL IBINIT1 (IBFIND, IBTRG, IBCLR, IBPCT, IBSIC, IBLOC, IBPPC, IBNA, IBONL,
        IBRSC, IBRE, IBRSV, IBPAD, IBSD, IBIST, IBDMA, IBEOS, IBTMO, IBEOT, IBRDF,
        IBWRTF)
1260   CALL IBINIT2 (IBGTS, IBCAC, IBWAIT, IBPOKE, IBWRT, IBWRTA, IBCMD, IBCMDA,
        IBRD, IBRDA, IBSTOP, IBRPP, IBRSP, IBDIAG, IBXTRC, IBRDI, IBWRTI, IBRDIA,
        IBWRTIA, IBSTA%, IBERR%, IBCNT%)
1270 '
1280 DIM DAT$(500)           ' Ensure an array of 500 character
                            ' strings.
1290 '
1300 DEVICE$ = "TC100"      : CALL IBFIND(DEVICE$,TC%)      ' Device open
1310                               CALL IBSIC(TC%)          ' Interface clear
1320 '
1330 CMD$ = "HEAD ON"       : CALL IBWRT(TC%,CMD$)          ' Specify together with the time
                            ' data.
1340 '
1350 CMD$ = "DHOL ON"       : CALL IBWRT(TC%,CMD$)          ' Display holds.
1360 '
1370 CMD$ = "BLOC 500"      : CALL IBWRT(TC%,CMD$)          ' Sample 500 data items at high
                            ' speed.
1380 '
1390 FOR I=1 TO 500         ' Loops 500 times
1400 '
1410   DAT$ = SPACE$(80) : CALL IBRD(TC%,DAT$)              ' Read in measurements to the
                            ' character variable DAT$.
1420   DAT$(I) = LEFT$(DAT$, IBCNT%-2)                      ' Reshape into a character string
                            ' of up to the number of received
                            ' characters - 2.
1430   PRINT DAT$(I)                                         ' Display the measurement.
1440 '
1450 NEXT                   ' Loop end
1460 '
1470 END                   ' End

```

Chapter 7

TROUBLESHOOTING, MAINTENANCE, CALIBRATION, AND ADJUSTMENT

7.1	Experiencing Failure? First, Make an Examination Yourself	7-2
7.2	Implications of Error Codes and Their Countermeasures	7-3
7.3	Executing Self-diagnosis	7-4
7.4	Calibration and Adjustment	7-6
7.5	Office to Contact if a Failure Occurs	7-8

7.1 Experiencing Failure? First, Make an Examination Yourself

Measures When Failure Occurs

- If the counter does not properly operate even after the following measures are taken, carry out the various tests described in **Section 7.3 “Executing Self-diagnosis” (page 7-4)**. If servicing is required or the causes of the failure are not clarified even after the following measures are taken and the various tests are executed, contact your nearest Sales/Service center. Addresses may be found on the back cover of this manual.

Problem	Probable Cause	Countermeasures	Refer to Page
The power to the counter cannot be turned on.	Power supply which is out of the rated power range is used.	Use the appropriate power supply.	2-11
	System error or the like occurs due to external noise and other causes.	Turn the power switch on while pressing the  key . However, settings and the like stored in the memory will be lost. The settings returns to their default values (see page 4-6).	—
Key operation is impossible.	Remote state	Change to the local state by pressing the LOCAL key .	1-7 6-4
	Others	Implement tests on the keys. If any failure is found, servicing may be necessary.	7-4
Measurement is not proper.	Ambient temperature and humidity are not in the permissible operating ranges.	Use the counter in an environment conforming to the specifications.	2-6 9-7
	Warm-up time is not sufficient.	After turning on power, allow the counter to warm up for at least 30 minutes.	—
	The trigger level is not proper.	Select auto-trigger; otherwise, set the trigger level to an appropriate value with manual triggering.	3-6
	Scaling has been performed.	Release the PROG command.	5-12
Setting and operation control through the GP-IB interface cannot be made.	The address of the TC100 series counter referred to by the program differs from the set address.	Use the same address for the program and the TC100 series counter.	6-6
	The same address is used for both the TC100 series counter and the equipment connected to others.	Change the address of the TC100 series counter to a different one from that of the connected equipment.	6-6
	The GP-IB interface used does not conform to the electrical and mechanical specifications (IEEE St'd 488-1978).	Use the interface in a manner conforming to the specifications.	—

7.2 Implications of Error Codes and Their Countermeasures

In this section, the implications of error codes presented on the display and their countermeasures are described.

Error Codes

- An error number is displayed. This appears when a setting whose execution is impossible is attempted or the counter system encounters an abnormal state.

Category	Error Number	Implication and Countermeasures	Refer to Page(s)
Communication error	113	This is an undefined command. Check the command.	6-9 to 6-21
	120	Numeric value data for a parameter are in error. Check the parameter.	6-9 to 6-21
	140	Character data for a parameter are in error. Check the parameter.	6-9 to 6-21
	221	Setting is impossible in the current state. Check the restrictions on the setting.	Chapter 6
	222	The parameter is beyond the settable range. Check the settings.	Chapters 3, 4, and 5
Measurement error	301	Measurement exceeded the measuring range. Check the measurable range.	—
System error/others	501	The system ROM has failed. Servicing is required.	—
	502	The system RAM has failed. Servicing is required.	—
	503	The cooling fan has stopped. Immediately turn off power. If the problem recurs even after a restart, servicing is required.	—

Note

- The above errors may be caused by externally intruding noise. If the counter does not return to normal even though countermeasures to each category of errors are taken, or if a system error is displayed, turn on the power switch while pressing the  key. However, settings and others stored in the memory will be lost. The settings return to their default values (see page 5-6).

When Servicing Is Required

Contact your nearest Sales/Service center. Addresses may be found on the back cover.

7.3 Executing Self-diagnosis

Before Starting

- **Types of self-diagnosis functions**
 - **Self-testing**
This is a test to check whether the TC100 series counter functions are normal or not.
 - **Panel-key testing**
This is a test to check whether the front panel-key functions are normal or not.
 - **Display testing**
This is a test to check whether each LED on the display lights up properly or not.

Operation Procedure

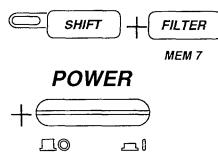

- **Self-testing**

- 1. By turning on the power while pressing the (SHIFT+FILTER) keys, self-testing is executed.**

During the test, the words [tEST 1] to [tEST 10] flash in turn on the display.

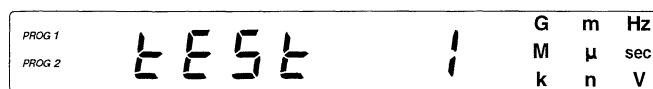

- 2. When the test is completed, [PASS] is displayed.**

If a failure is found, the word [FAiL] and a following failure number are displayed. When a failure number is displayed, the TC100 series counter does not properly operate. In this case, turn off the power switch and contact your nearest Sales/Service center. Addresses may be found on the back cover. Inform the Sales/Service center of the model and serial number marked on the name plate on the rear panel, and the displayed failure number.

- Display after normal termination

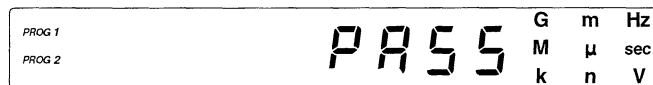

- Display after failure

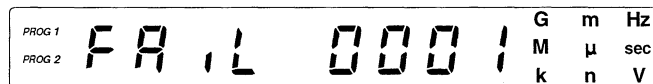

- Failure numbers

Failure No.	Implications and Countermeasures
0001	The battery is drained. The current panel settings and stored information cannot be retained. Request battery replacement.
0004 and up	Failure(s) may be present in the hardware. Request repair.

- 3. Once turn off and then turn on the power again to exit from the self-test menu.**

Note

- When self-testing is to be done, nothing should be connected to the I/O terminals.
- If self-testing is done with any circuits connected to the I/O terminals, a failure number may be displayed.

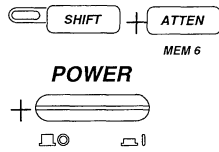

• **Panel-key testing**

1. Turn on the power while pressing the (SHIFT+ATTEN) keys.

- When any front panel key is pressed, the number corresponding to the key is displayed.
- If **TRIG** key is pressed,



- If no response is obtained by pressing a front panel key, turn off the power switch and contact your nearest Sales/Service center. Addresses may be found on the back cover. Inform the Sales/Service center of the model and serial number marked on the nameplate on the rear panel, and the key for which no response is obtained.

2. Once turn off and then turn on the power again to exit from the panel-key test menu.

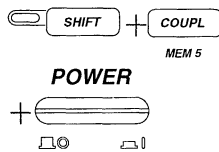

• **Display Testing**

1. Display testing is executed by turning on the power while pressing the (SHIFT+COUPL) keys.

Immediately after execution of the test, all LEDs (except input LEDs for each channel) are lit. The LEDs on the display are then lit in turn.

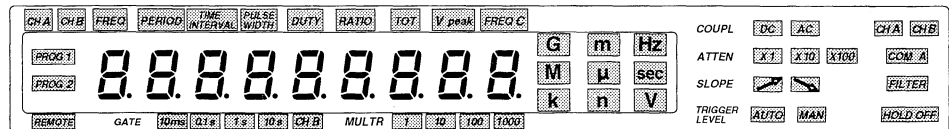

2. Once turn off and then turn on the power again to exit from the display test menu.

7.4 Calibration and Adjustment

Calibration of Reference Frequency

In universal counters, the accuracy of the reference frequency is the basis for all measurements. In this section, the method for calibrating the accuracy of the internal reference frequency is described.

Frequency Standard Unit

To check the accuracy of the reference frequency, a frequency standard unit is necessary. Since stabilities of the crystal oscillators used in TC100 series counters are

Standard crystal : $\pm 1.5 \times 10^{-6}$ /year
 $\pm 3 \times 10^{-6}$ (5 to 40°C), or
Highly stable crystal : $\pm 1 \times 10^{-7}$ /year
 $\pm 1 \times 10^{-7}$ (5 to 40°C),

higher stable crystals are necessary as a standard unit.

The standard unit generally and frequently used is a Rubidium (Rb) atom oscillator. Although this is itself a secondary standard and requires calibration, it is sufficient for the calibration of TC100 series counters because its stability is very high.

Calibration Method

Measuring instruments to be prepared:

Rb atom frequency oscillator, FC6011B (manufactured by Fujitsu), equivalent to HP5065A (manufactured by HP)

Frequency counter, TA1100 (manufactured by YOKOGAWA), equivalent to HP5370B (manufactured by HP)

• Connection

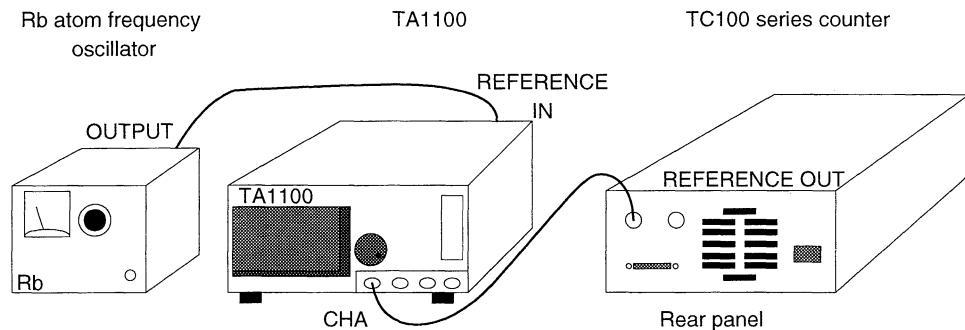

• Calibration method

Measure the frequency of the reference output (REFERENCE OUT) of a TC110/120 counter with a frequency counter (TA1100) which connects the Rb atom frequency oscillator output to its external reference signal input (REFERENCE IN).

If a TA1100 is used for the frequency counter, eleven significant digits can be obtained for a gate time set to 1 [s] because TA1100 counter time resolution for a single shot is very high, such as 20 [ps rms]. This means that an accuracy of 1 [mHz] or better is obtained when 10 [MHz] is measured.

Since the TA1100 frequency counter has the reference frequency as the standard frequency, frequency calibration is possible using this method.

Adjustment Method If a Highly Stable Timebase Is Incorporated

Frequency cannot be adjusted in models which incorporate a standard timebase. However, if an optional highly stable timebase is incorporated, those models are adjustable. As a frequency adjustment trimmer is provided on the rear panel, adjustment can be made using a flat-blade screwdriver.

Adjustment is made using the same frequency counter as used in frequency calibration.

Adjustable Range

The crystal oscillator frequency varies while adjustment is made. The short-term frequency change is as shown below for the optional timebase as described in **Section 9.4, "Optional Specifications"** (page 9-6), a description of short-term stability.

Short-term stability = $\pm 5 \times 10^{-10}$ (rms/s)

This means that a 10-MHz oscillation frequency varies by the following effective value (standard deviation) per second:

$10 \text{ (MHz)} \times (\pm 5 \times 10^{-10}) = \pm 5 \text{ (mHz rms)}$

In addition, if the maximum value of the varying frequency is assumed to be three times the standard deviation (3σ),

$3 \times [\pm 5 \text{ (mHz rms)}] = \pm 15 \text{ (mHz)}$

is obtained. Hence, the adjustable range may be the following value through the consideration of adjustment carried out over tens of seconds:

$10 \text{ (MHz)} \pm 100 \text{ (mHz)}$

That is, the limit is assumed to be $\pm 1 \times 10^{-8}$.

7.5 Office to Contact if a Failure Occurs

If Repair Is Required

Repair may be necessary in the following cases:

- For problems that cannot be treated in **Section 7.1, “Experiencing Failure? First, Make an Examination Yourself”** (page 7-2) or **Section 7.2, “Implications of Error Codes and Their Countermeasures”** (page 7-3).
- For failures found in executing self-diagnosis (**Section 7.3, “Executing Self-diagnosis”** on page 7-4).
- For other cases where the equipment is clearly considered to have failed.

Office to Contact if a Failure Occurs

Request repair from your nearest Sales/Service center. Addresses may be found on the back cover.

Chapter 8

PERFORMANCE TESTING

8.1	Preparing for Performance Testing	8-2
8.2	Doing the Performance Test	8-3
8.2.1	Testing Input Sensitivity	8-3
8.2.2	Test for Frequency Measurement Accuracy	8-4
8.2.3	Test for Time Interval Measurement Accuracy	8-5

8.1 Preparing for Performance Testing

Purpose of Performance Testing

The purpose of performance testing is to examine whether TC100 series counters meet their specifications. If the measurements in each performance test exceed the criteria, adjustment and/or repair will be necessary. Request the repair and/or adjustment from your nearest Sales/Service center. Addresses may be found on the back cover.

Equipment Required for Performance Tests

The following are the equipment necessary for executing the performance tests described in Section 8.2:

Frequency Synthesizer	HP 8657B or equivalent
Waveform Generator	YOKOGAWA Electric AG2200 (Model 705022) or equivalent
Time-interval Analyzer	YOKOGAWA Electric TA1100 (Model 704020) or equivalent
Frequency Standard	HP 5065A or equivalent
Coaxial Cable	Two cables with 50 Ω BNC connector

Environment in Which Testing Is Carried Out

- **Warm-up time for equipment necessary for performance testing and the TC100 series counter under test**
30 minutes or more
- **Operating Condition in which performance testing is carried out**
 - Ambient temperature : 23°C \pm 2°C
 - Ambient humidity : 50 \pm 10% RH
 - Supply voltage : 100 V AC \pm 1%
 - Use coaxial cables to connect the measuring instruments to the TC100 series counter.

8.2 Doing the Performance Test

8.2.1 Testing Input Sensitivity

- **Instrument to be used for testing**

Frequency synthesizer

- **Testing procedure**

1. **Set the TC100 series counter under testing and the frequency synthesizer as shown below.**

- **TC100 series counter**

Measurement function : frequencies A, B, and C
Gate time : 1 sec
Trigger level : 0 V
ATTEN : $\times 1$
External reference signal : input from the synthesizer

- **Synthesizer**

Level : as shown below
Frequency : as shown below

* Calibrate the accuracy of the synthesizer level within ± 0.1 dB in advance.

2. **Connect the output of the synthesizer to channel A of the TC100 series counter.**

- **Criteria**

Channel A or B	50 mVrms	DC < input frequency \leq 60 MHz
	100 mVrms	60 MHz < input frequency \leq 120 MHz

Channel C	-20 dBm	100 MHz \leq input frequency < 1 GHz
	-10 dBm	1 GHz \leq input frequency < 2 GHz

Testing should be carried out for the following frequencies and levels. Also, use sinusoidal waves as the synthesizer output.

- **For channel A or B**

Measuring frequency	Level	Criterion
100 kHz	50 mVrms	100 kHz \pm 0.1 Hz
1 MHz	50 mVrms	1 MHz \pm 1 Hz
60 MHz	50 mVrms	60 MHz \pm 10 Hz
120 MHz	100 mVrms	120 MHz \pm 20 Hz (only for channel A)

- **For channel C**

Measuring frequency	Level	Criterion
100 MHz	-20 dBm	100 MHz \pm 100 Hz
1 GHz	-20 dBm	1 GHz \pm 1 kHz
1.3 GHz	-10 dBm	1.3 GHz \pm 1 kHz
2 GHz	-10 dBm	2 GHz \pm 2 kHz

8.2.2 Test for Frequency Measurement Accuracy

- **Instruments to be used for testing**

Frequency synthesizer
Frequency standard

- **Testing procedure**

1. **Set the TC100 series counter under testing and the frequency synthesizer as shown below.**

- **TC100 series counter**

Measurement function : frequency A
Gate time : 1 sec
Trigger level : 0 V
ATTEN : × 1

- **Synthesizer**

External reference input (input from the frequency standard)
Level : ±10 dBm (4 Vp-p at high impedance loading)

2. **Connect the output of the synthesizer to channel A of the TC100 series counter.**

- **Criteria**

$$\frac{\pm 10 \text{ ns} \pm \sqrt{2} \times \text{Trigger error}}{\text{Gate time}} \times \text{Measuring frequency} \pm (\text{Timebase aging} \times \text{measuring frequency}) \dots (1)$$

Carry out testing for the following frequencies:

Measuring frequency	Criterion
100 kHz	100 kHz ± 350 mHz
10 MHz	10 MHz ± 35 Hz
120 MHz	120 MHz ± 420 Hz

- **Example of criteria calculation**

Calculation of the criteria is shown below for a 100 kHz frequency test carried out with a model incorporating a standard crystal oscillator. It is assumed that the reference frequency of the TC100 series counter under testing is adjusted to within 2 ppm and that one year has elapsed since the above adjustment. It is also assumed that the noise at the counter input block is 600 μVrms (a representative value). No signal noise is considered.

$$\text{Trigger error} = \frac{\sqrt{X^2 + E_n^2}}{\text{Slew rate}} = \frac{600 \mu\text{Vrms}}{2 \times \pi \times 100 \text{ kHz} \times 2 \text{ V}}$$

If it is assumed as shown above (for trigger errors, see page 4-16 ; X = counter input block noise; E_n = signal noise; the slope at the point where the sinusoidal wave intersects the zero line is 2 πfA (V/s), where A is the amplitude and f the frequency), the expression (1) is as follows:

$$\frac{\pm 10 \text{ ns} \pm \sqrt{2} \times \frac{600 \mu\text{Vrms}}{2 \times \pi \times 100 \text{ kHz} \times 2 \text{ V}}}{1 \text{ s}} \times 100 \text{ kHz} \pm [(2 + 1.5) \times 10^{-6}] \times 100 \text{ kHz}$$

≈ ±350 mHz

8.2.3 Test for Time Interval Measurement Accuracy

- **Instruments to be used for testing**

Waveform Generator
Time interval analyzer
Frequency standard

- **Testing procedure**

1. **Calibrate the phase difference between two-channel outputs of the waveform generator using the time interval analyzer. For the phase difference, calibrate it for 10 μs and 500 ns; then note the calibrated values as X₁ and X₂, and use them as the testing signals.**

2. **Set the TC100 series counter and the waveform generator as shown below.**

- **TC100 series counter**

Measurement function Time interval
Multiplier : 1
Trigger level : 0 V
ATTEN : × 1

- **Waveform generator**

External reference input (from the frequency standard)
Waveform : rectangular wave
Level : ±0.5 V
(at high impedance load)
Frequency : 1 kHz
Pulse width : 500 ns
Rise : 10 ns or less
Phase difference between two channels : 10 μs or 500 ns

3. **Connect the CH1 output of the waveform generator to channel A of the TC100 series counter and the CH2 output to channel B.**

- **Criteria**

$$\frac{(\pm 10 \text{ ns} \pm \text{Channel A input trigger error} \pm \text{Channel B input trigger error})}{\sqrt{\text{Square root of multiplier}}}$$

$$\pm(\text{Timebase aging} \times \text{measuring time}) \pm \text{Trigger-level timing error} \\ \pm 10 \text{ ns Inter-channel error} \quad \dots(1)$$

Carry out the test for the following phase differences:

Phase difference between two channels	Calibrated value	Criterion
10 μs	X ₁	X ₁ ± 20.6 ns
500 ns	X ₂	X ₂ ± 20.6 ns

- **Example of criteria calculation**

Calculation of the criteria is shown below for a time interval test. It is assumed that the reference frequency of the TC100 series counter under testing is adjusted to within 2 ppm and that one year has elapsed since the above adjustment. It is also assumed that the noise at the counter input block is 600 μVrms (a representative value). No signal noise is considered.

$$\text{Trigger error} = \frac{\sqrt{X^2 + E_n^2}}{\text{Slew rate}} = \frac{600 \mu\text{Vrms}}{1 \text{ V}/10 \text{ ns}}$$

If it is assumed as shown above (for trigger errors, see page 4-16 ; X = counter input block noise and E_n = signal noise), the expression (1) is as follows:

$$\frac{\pm 10 \text{ ns} \pm 600 \mu\text{Vrms}/100 \text{ V}/\mu\text{s} \pm 600 \mu\text{Vrms}/100 \text{ V}/\mu\text{s}}{\sqrt{1}}$$

$$\pm(3.5 \times 10^{-6}) \times 10 \mu\text{s}$$

$$\pm \left(\frac{20 \text{ mV}}{100 \text{ V}/\mu\text{s}} - \frac{20 \text{ mV}}{100 \text{ V}/\mu\text{s}} \right) \pm \frac{30 \text{ mV}}{100 \text{ V}/\mu\text{s}} \pm \frac{30 \text{ mV}}{100 \text{ V}/\mu\text{s}}$$

$$\pm 10 \text{ ns}$$

$$\approx \pm 20.6 \text{ ns}$$

Chapter 9

SPECIFICATIONS

9.1	Specifications for Each Measurement Function	9-2
9.2	Input Block Specifications	9-5
9.3	Reference Time Specifications	9-6
9.4	Optional Specifications	9-6
9.5	General Specifications	9-8
9.6	External Dimensions	9-9

9.1 Specifications for Each Measurement Function

Frequency, Channel A (FREQ)

Item	Specification(s)	
Measuring range	1 Hz to 120 MHz (1/2-prescaler)	1 Hz to 60 MHz
Gate time*5	10 ms, 100 ms, 1 s, or 10 s	CHB gate (channel B pulse width)
Unit displayed	Hz, kHz, or MHz	
Resolution	$\frac{\pm 10 \text{ ns} \pm \sqrt{2} \times \text{Trigger error}^{*2}}{\text{Gate time}} \times \text{Measured frequency (Hz)}$	
Accuracy*1	Resolution \pm (Timebase aging \times measured frequency) (Hz)	

Frequency, Channel B (FREQ)

Item	Specification(s)	
Measuring range	1 mHz to 60 MHz	
Gate time*5	10 ms, 100 ms, 1 s, or 10 s	
Unit displayed	mHz, Hz, kHz, or MHz	
Resolution	$\frac{\pm 10 \text{ ns} \pm \sqrt{2} \times \text{Trigger error}^{*2}}{\text{Gate time}} \times \text{Measured frequency (Hz)}$	
Accuracy*1	Resolution \pm (Timebase aging \times measured frequency) (Hz)	

Frequency, Channel C (FREQ)

Item	Specification(s)	
Measuring range	100 MHz to 2 GHz (1/128-prescaler)	
Gate time*5	10 ms, 100 ms, 1 s, or 10 s	
Unit displayed	MHz or GHz	
Resolution	$\frac{\pm 10 \text{ ns} \pm \sqrt{2} \times \text{Trigger error}^{*2}}{\text{Gate time}} \times \text{Measured frequency (Hz)}$	
Accuracy*1	Resolution \pm (Timebase aging \times measured frequency) (Hz)	

Period, Channel B (PERIOD)

Item	Specification(s)	
Measuring range	20 ns to 999.999999 s	
Multiplier	1, 10, 100, or 1000	
Unit displayed	ns, μ s, ms, or s	
Resolution	$\frac{\pm 10 \text{ ns} \pm \sqrt{2} \times \text{Trigger error}^{*2}}{10^N} \text{ [s]}$ (10^N denotes the scaling factor; N = 0, 1, 2, or 3)	
Accuracy*1	Resolution \pm (Timebase aging \times measured frequency) (Hz)	

*1: Value measured after a warm-up period of 30 minutes in the reference operating condition noted on page 9-8.

*2: Refer to page 9-4.

*5: Refer to page 9-4.

Time Interval, Channel A → Channel B (TIME INTERVAL)

Item	Specification(s)
Measuring range	60 ns to 999.999999 s
Input frequency range	A, B: 1 mHz to 50 MHz
Multiplier	1, 10, 100, or 1000
Unit displayed	ns, μs, ms, or s
Dead time	200 ns (in the case where the multiplier = 10, 100, or 1000)
Resolution	$\frac{\pm 10 \text{ ns} \pm A\text{-input trigger error}^{*2} \pm B\text{-input trigger error}^{*2}}{\sqrt{10^N}} \text{ [s]}$ (10 ^N denotes the scaling factor.) N = 0, 1, 2, or 3
Accuracy*1	Resolution ±(Timebase aging × measured time) ±trigger level timing error*3 ±10 ns interchannel error*4

Pulse Width, channel B (PULSE WIDTH)

Item	Specification(s)
Measuring range	20 ns to 999.999999 s
Multiplier	1, 10, 100, or 1000
Unit displayed	ns, μs, ms, or s
Resolution	$\frac{\pm 10 \text{ ns} \pm \text{Rising-edge trigger error}^{*2} \pm \text{Falling-edge trigger error}^{*2}}{\sqrt{10^N}} \text{ [s]}$
Accuracy*1	Resolution ±(Timebase aging × measured time) ±trigger level timing error*3

Duty Ratio, Channel B (DUTY)

Item	Specification(s)
Measuring range	0.00000001 to 0.99999999
Input range	20 ns to 999.999999 ns
Multiplier	1, 10, 100, or 1000
Unit displayed	Percents (0.5 reads as 50%)
Resolution	$\pm \left(\frac{\text{Pulse width} + \text{Pulse-width resolution}}{\text{Period} - \text{Resolution of period}} - \text{Measured duty value} \right)$
Accuracy*1	$\pm \left(\frac{\text{Pulse width} + \text{Pulse-width accuracy}}{\text{Period} - \text{Accuracy of period}} - \text{Measured duty value} \right)$

Frequency Ratio, Channel A/Channel B (RATIO)

Item	Specification(s)
Measuring range	A, B: 1 mHz to 60 MHz Displays 0 in the case of A < B if multiplier = 1)
Multiplier	1, 10, 100, or 1000
Unit displayed	μ, m, k, or M
Resolution	$\frac{\pm 1 \text{ count of channel A input} \pm \sqrt{2} \times \text{Channel B input trigger error}^{*2}}{10^N}$ (10 ^N denotes the scaling factor.) N = 0, 1, 2, or 3
Accuracy*1	Resolution

*1: Value measured after a warm-up period of 30 minutes in the reference operating condition noted on page 9-8.
 *2: Refer to page 9-4.
 *3: Refer to page 9-4.
 *4: Refer to page 9-4.

9.1 Specifications for Each Measurement Function

Totalization, Channel A (TOT)

Item	Specification(s)
Input frequency range	1 mHz to 50 MHz
Counting capacity	0 to 999999999
Counting error	±1 count in measurement by channel B gating
Counting control	Manual start, or channel B gating (pulse width)

Number of Revolutions, Channel B (rpm)

Item	Specification(s)
Measuring range	60 mrpm to 120 Mrpm
Gate time*5	10 ms, 100 ms, 1 s, or 10 s
Unit displayed	mrpm, rpm, krpm, or Mrpm
Resolution	$\frac{\pm 10 \text{ ns} \pm \sqrt{2} \times \text{Trigger error}^{*2}}{\text{Gate time}} \times \text{Measured number of revolutions [rpm]}$
Accuracy*1	Resolution ±(Timebase aging × measured number of revolutions) [rpm]

Peak Voltage, Channels A and B (Vpeak)

Item	Specification(s)
Voltage measuring range	±5 V (ATT = ×1)
Frequency range	50 Hz to 20 MHz
Accuracy	20 mV
Measurement error*1	±10% ±40 mV (ATT = ×1) of reading for sine wave
Dynamic range	250 mVp-p to 5 Vp-p

*1: Value measured after a warm-up period of 30 minutes in the reference operating condition noted on page 9-8.

$$*2: \text{Trigger error} = \frac{\sqrt{X^2 + E_n^2}}{\text{S.R.}} \text{ [s]}$$

where X : Noise at counter input (600 μVrms),

En : Signal noise (Vrms) in the frequency band of the input amplifier (120 MHz),

S.R.: Slew rate (V/s) of the input signal at the trigger level.

$$*3: \text{Trigger level timing error} = \left(\frac{20 \text{ mV}}{\text{S.R.}(\text{START})} - \frac{20 \text{ mV}}{\text{S.R.}(\text{STOP})} \right) \pm \frac{\text{Trigger level setting accuracy}}{\text{S.R.}(\text{Start})} \pm \frac{\text{Trigger level setting accuracy}}{\text{S.R.}(\text{Stop})} \text{ [s]}$$

Where S.R.(START) : Slew rate (V/s) of the input signal at the trigger level of channel A input (for time interval measurement), and slew rate (V/s) of the rising/falling slope (for pulse width measurement).

Where S.R.(STOP) : Slew rate (V/s) of the input signal at the trigger level of channel B input (for time interval measurement), and slew rate (V/s) of the rising/falling slope (for pulse width measurement).

*4: 10 ns interchannel error = error due to the difference in the internal delays on channels A and B

*5: In the case where one period of input frequency exceeds the setting gate time, the gate time will be forced to become one period time of input signal.

9.2 Input Block Specifications

Input to Channels A and B

Item	Specification(s)
Input impedance	1 M Ω /45 pF (typical) (mode for independent input to channels A and B) 500 k Ω /80 pF (typical) (mode for common input to channels A and B)
Coupling	DC, AC, AC coupling: 35 Hz cutoff frequency
Attenuator	$\times 1$, $\times 10$, $\times 100$
Trigger level	-5 V to +5 V (ATT = $\times 1$, 20 mV resolution) -50 V to +50 V (ATT = $\times 10$, 200 mV resolution) -250 V to +250 V (ATT = $\times 100$, 2 V resolution) Setting accuracy*1: $\pm 6\%$ of setpoint ± 30 mV (ATT = $\times 1$) Slope: Selection of + or - slope Display: 7-segment LEDs with SETTING or DISPLAY key
AUTO trigger	Automatic setting at half of the input amplitude Operating frequency range = Sine wave of 50 Hz to 120 MHz Sensitivity = 250 mVrms Setting accuracy*1 = ± 100 mV (to signals crossing the 0-V level)
Operating voltage range	± 5 V (at ATT = $\times 1$)
Input sensitivity*1	50 mVrms: DC < input frequency \leq 60 MHz 100 mVrms: 60 MHz < input frequency \leq 120 MHz
Maximum input voltage	250 V (DC + ACpeak): DC \leq input frequency < 5 MHz $\left(\frac{1.2 \times 10^3}{f[\text{MHz}]} \right)$ [V(DC + ACpeak)] 5 MHz \leq input frequency < 120 MHz
Rejection of superimposed noise	100 kHz (-3 dB) first-order low-pass filter
Holdoff	Ignores the input signal only for a specified duration (with the multiplier fixed at 1). In a time interval measurement, ignores the CHB input only for a specified duration from CHA input. Operating voltage range: 1 mHz to 10 kHz Setting resolution of 100 μ s to 1 ms: allows setting in 100 μ s increments Setting resolution of 1 ms to 10 m: allows setting in 1 ms increments Setting resolution of 10 ms to 100 ms: allows setting in 10 ms increments Setting accuracy: ± 100 μ s
COM A	Switching of independent/common input modes for channels A and B
Channel B gate input	Gate signal for frequency A counting and totalization Input range: Gate setting pulse width is 100 ns to 100 s (The number of channel A input periods within the gate time should not exceed 2 ³² .) CHB gate time > One period of the channel A input signal
Minimum input pulse width*1	10 ns (except for the measurement function of frequency A)

Channel C Input

Item	Specification(s)
Input impedance	50 Ω
Coupling	AC
Attenuator	$\times 1$
Dividing ratio	1/128
Operating voltage range*1	+13 dBm
Maximum input voltage	+30 dBm
Input sensitivity*1	-20 dBm: 100 MHz \leq input frequency < 1 GHz -10 dBm: 1 GHz \leq input frequency \leq 2 GHz

*1: Values measured after a warm-up period of 30 minutes in the reference operating condition noted on page 9-8.

9.3 Reference Time Specifications

Item	Specification(s)
Internal reference frequency	10 MHz
Frequency stability* ¹	Aging rate : $\pm 1.5 \times 10^{-6}$ /year
	Temperature characteristic : $\pm 3 \times 10^{-6}$ (5 to 40°C)
Reference output	Frequency : 10 MHz (typical)
	Output level : 1 V _{p-p} (50Ω)
	Output waveform : rectangular
External reference input* ¹	Frequency : 10 MHz \pm 10 Hz
	Input level : 1 to 7 V _{p-p} Duty ratio ranging from 40 to 60% for pulse signals
	Coupling : AC
	Input impedance : 1 kΩ or greater

*1: Value measured after a warm-up period of 30 minutes in the reference operating condition noted on page 9-8.

9.4 Optional Specifications

High stability timebase

Item	Specification(s)
Crystal oscillator	Digital, temperature-compensated crystal oscillator
Frequency	10 MHz
Frequency stability* ¹	Aging rate : $\pm 1 \times 10^{-7}$ /year (Typical)
	: $\pm 3 \times 10^{-7}$ /year (Max)
	Temperature characteristic : $\pm 1 \times 10^{-7}$ (5 to 40°C)
	Short-term stability : $\pm 5 \times 10^{-10}$ rms/s

D/A Output Function

Item	Specification(s)
Output voltage range	0 to +10 V (with high-impedance load)
	Linear conversion full scale 15 bits D/A
Setting range	Sets the maximum and minimum value in 6 digits in the range of D/A conversion
Response time	4 ms or longer
Output-terminal	BNC connector

*1: Value measured after a warm-up period of 30 minutes in the reference operating condition noted on page 9-8.

Handler interface Function

Electrical Specifications

I/O terminal	Item			/H1 (Optional)	/H2 (Optional)
Input terminal /EXT_TRIG	Input type			Photo-coupler cathode input	
	Isolation			By photo-coupler	Not isolated
	Power supply system			External	Internal (+5V)
	Operating voltage/ current	Power supply +12 V DC	ON	2 V or less/ 3 mA or more	—
			OFF	8 V or more/ 1 mA or less	—
		Power supply +24 V DC	ON	12 V or less/ 3 mA or more	—
			OFF	20 V or more/ 1 mA or less	—
		Power supply, internal	ON	—	1 V or less/ 3 mA or more
			OFF	—	3 V or more 1 mA or less
	Maximum input voltage			Power supply voltage +5 V DC	
Minimum input pulse width			1 μs		
Output terminal /BIN1 /BIN2 /BIN3 /LOW /HIGH /EOM	Output type			Open collector output	
	Isolation			By photo-coupler	Not isolated
	Rated load voltage			12 to 24VDC	
	Rated output voltage ON			0.5 V or less	
	OFF			12 to 24V	
	Maximum load current			30 mA/point	
	Leakage current in OFF state			0.1 mA or less	
	DC power supply DCV	Applied voltage range			12 to 24VDC
Common terminal COM	COM terminal potential			External potential (isolated)	Internal potential (not isolated)

*1: Value measured after a warm-up period of 30 minutes in the reference operating condition noted on page 9-8.

General Specifications

Maximum counting frequency (in totalization mode)	10MHz	
Setting data	Setpoint	Always four data items (only 1 data item in totalization mode) SET1, SET2, SET3, and SET4 (only SET1 in totalization mode) However, the following must be met: SET1 ≤ SET2 ≤ SET3 ≤ SET4
	Setting range	Up to 6 digits can be set in all functions. 0.00001n to 999.999M (for TC110) 0.00001n to 999.999G (for TC120)
Judgment delimitation	Judgment delimitation is carried out in up to 5 ranks. Delimitation can be reduced by making setpoints common.	
Output data	X < SET1 : /LOW SET1 ≤ X < SET2 : /BIN1 SET2 ≤ X < SET3 : /BIN2 SET3 ≤ X < SET4 : /BIN3 SET4 ≤ X : /HIGH (X represents a measured value.)	
Timeout time	If a signal is not input for a specified time after an /EXT_TRIG input, measurement is halted by outputting /EOM.	
	Time setting range	t × 10 ⁿ s t=1, 2, 5 or OFF n=-2, -1, 0, 1, 2

9.5 General Specifications

Item	Specification(s)				
Reference operating condition	Ambient temperature : $23 \pm 2^\circ\text{C}$ Ambient humidity : $50 \pm 10\%$ RH Power supply voltage : $100 \text{ V} \pm 1\%$				
Warm-up time	Approximately 30 minutes (to satisfy all specifications)				
Display	7-segment red LEDs for 9 decimal places Displayed digit masking function : Allows up to 9 of the lower digits to be masked.				
Sampling rate	4 ms or greater, or hold Peak voltage measurement : 20 ms				
Memory function	Can store/recall eight types of panel setting information with the STORE/RECALL key (Non-volatile memory)				
Scaling function (PROGRAM)	The following algebraic expression is possible for any measurement function except the peak-voltage measurement: $aX + b$ Where X: the measured value, <table style="margin-left: 40px; border: none;"> <tr> <td style="padding-right: 10px;">a : the scale factor (the multiplying factor),</td> <td rowspan="2" style="font-size: 2em; vertical-align: middle;">}</td> <td rowspan="2">Two different patterns can be set for each measured value (PROG1, PROG2).</td> </tr> <tr> <td>b : the offset.</td> </tr> </table> Setting range : $a = \pm 0.001$ to ± 999.999 with up to 6 digits possible $b = 0$ or $\pm 0.001 \text{ n}$ to $\pm 999.999 \text{ M}$ with up to 6 digits possible	a : the scale factor (the multiplying factor),	}	Two different patterns can be set for each measured value (PROG1, PROG2).	b : the offset.
a : the scale factor (the multiplying factor),	}	Two different patterns can be set for each measured value (PROG1, PROG2).			
b : the offset.					
Communication function	GP-IB interface (equipped as standard) Transfer rate : 5 ms or greater (200 data/1s) Standards : conforming to IEEE STD 448-1978 (JIS C1901 - 1987) Subsets : SH1, AH1, T5, L4, SR1, RL1, PP0, DC1, DT1, and C0 Size of internal memory : 1024 words maximum Sampling rate to memory : From 1 ms or 10 ms to 300 s, settable in 10 ms steps				
Operating temperature range	5 to 40°C				
Operating humidity range	35 to 85% R.H., where the maximum wet-bulb temperature is 29°C				
Storage temperature range	-20 to 60°C				
Power consumption	60 VA maximum				
Supply voltage range	100 V AC (Operating voltage range: 90 to 110 V AC) (For a supply voltage of 120 V AC or 230 V AC, specify when ordering.)				
Rated power supply frequency	0/60 Hz (Operating frequency range: 48 to 63 Hz)				
Withstand voltage (between power supply and case)	1.5 kV AC, for 1 minute				
Insulation resistance (between power supply and case)	500 V DC, 10 M Ω or greater				
External dimensions	Approximately $213 \times 100 \times 330$ mm (W \times H \times D)				
Weight	Approximately 3.6 kg (counter alone)				
Instrument cooling system	Forced-air cooling, rear discharge				
Installation attitude	Horizontal				
Battery backup	Setpoint backed up with a lithium battery				
Accessories	<ul style="list-style-type: none"> • One power cord • One adapter for a 3-/2-prong plug • One copy of user's manual (this manual) 				
Accessories (sold separately)	<ul style="list-style-type: none"> • Cable with BNC connectors • Conversion adaptor • Connection adaptor • 50 Ω terminator • Rack-mounting kit 				

9.6 External Dimensions

Unit:mm

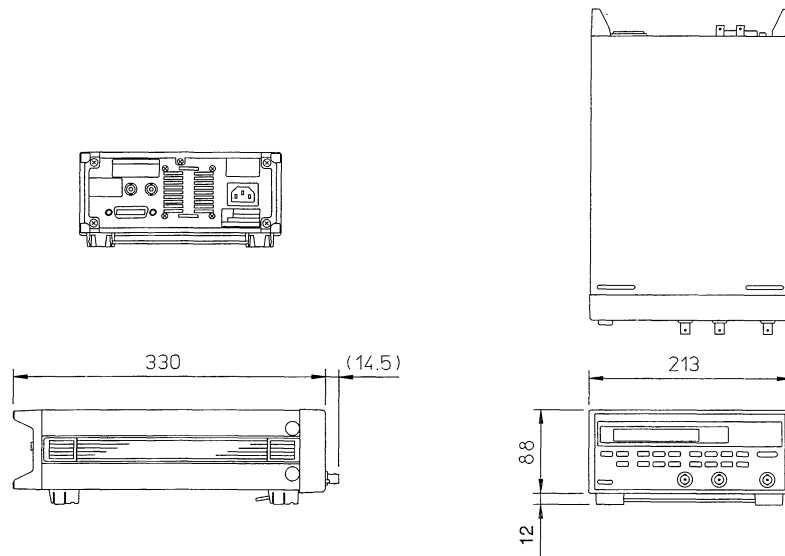

● JIS rack-mounting method

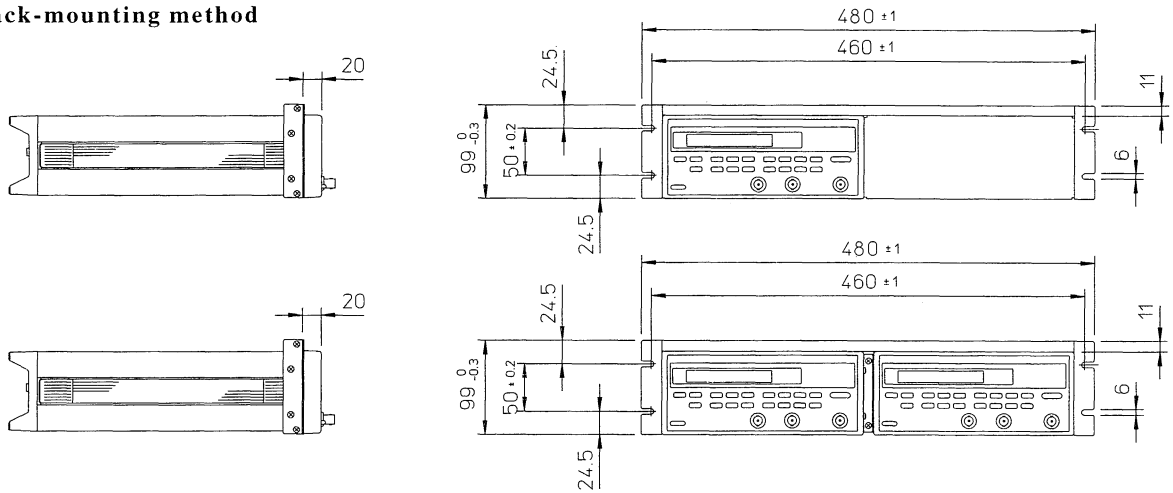

● EIA rack-mounting method

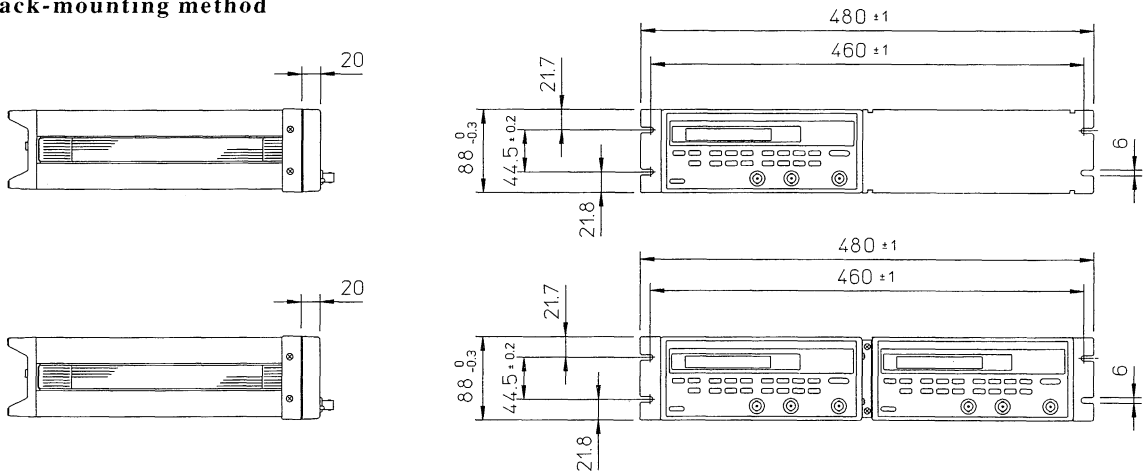

Weight of counter: approximately 3.6 kg

Tolerance not specifically indicated is ±0.3%. (±0.3 mm is applied to dimensions of less than 10 mm.)

INDEX

Alphabetical Index Index-2

Alphabetical Index

A Page

accessory	2-3
accuracy	4-15
address setting	6-6
adjustable range	7-7
aging rate	9-6
analog output	5-15
ATTEN key	3-4
attenuator	3-4
auto trigger	3-6

B Page

block diagram	1-3
---------------------	-----

C Page

calibration method	7-6
CH key	3-3, 3-4, 3-5
checking the reference signal	5-14
checking software	5-14
check of contents on delivery	2-2
changing display readout	4-13
COM A key	5-7
command list	6-9
common input	5-7
connection of power cord	2-11
conversion to any physical quantity	5-12
countermeasures to noise (attenuator, filter, and hold-off)	3-4, 3-5, 5-4
COUPL key	3-3

D Page

D/A output	5-15
DISP HOLD key	4-14
displayed-digit masking function	1-4, 5-13
display-hold function	1-4, 4-14
display hold-off LED	1-6
DISPLAY key	4-13
display panel	1-6
display test	7-5
duty ratio measurement	4-7
dynamic range	4-9

E Page

error code	7-3
external reference signal	5-8

F Page

filter	3-5
FILTER key	3-5
frequency measurement	4-2

frequency ratio measurement	4-8
front panel	1-7
FUNCTION key	4-2 to 12

G Page

GATE key	3-9
gate signal	3-8, 4-17
gate time	3-8, 4-17
gate time and resolution	4-17
general notes on usage	2-4
GP-IB interface specifications	6-3

H Page

hold-off function	1-4, 5-4
HOLD OFF key	5-5
hold-off time	5-4
hysteresis	3-4, 4-19

I Page

input block circuit diagram	5-8
input connection	2-14
input coupling	3-3
input impedance	2-14, 9-5
input terminal	1-7
input terminal LED	1-6
initialization (initialization of settings)	5-6
initialize	5-6
INITIALIZE key	5-6
inter-channel error	2-14
internal reference signal	5-8

L Page

LED of shift key	1-6
listener function	6-2
local	6-4
low-pass filter	3-5

M Page

manual trigger	3-6
maximum input voltage	2-14, 9-5
measured data output	6-7
measured data output format	6-7
measurement accuracy	4-15
measurement function	1-6
measurement of number of revolutions	4-12
measures when failure occurs	7-2
multiplier	3-9
MULTIPLIER key	3-9

N **Page**

names of components and their functions 1-6
 notice prior to programming 6-8
 numeric value setting 5-10

O **Page**

office to be contacted when failure occurs 7-8
 output block circuit diagram 5-9

P **Page**

panel-key test 7-5
 peak voltage measurement 4-9
 period measurement 4-4
 power consumption 2-11, 9-8
 PROGRAM key 5-12
 pulse width measurement 4-5

R **Page**

rack mounting 2-3, 2-7
 rear panel 1-8
 recall 5-3
 RECALL key 5-3
 reciprocal system 1-2
 reference signal output 5-9
 remote 6-4
 resolution 4-15

S **Page**

sample program 6-24 to 31
 scaling function 1-4, 5-12
 serial number 2-2
 self-diagnosis 7-4
 self-test 7-4
 SETTING key 3-7, 5-5, 5-10
 SHIFT key 1-6
 short-term stability 7-7
 slew rate (S.R.) 4-16, 4-19
 slope 3-6
 SLOPE key 4-2 to 12
 specifications
 external dimensions 9-9
 general 9-8
 input block 9-5
 measurement function 9-2
 optional 9-6
 reference time 9-6
 START key 4-10, 4-14
 status byte 6-5
 store 5-2
 STORE key 5-2

T **Page**

talker function 6-2
 terminator 6-6
 timebase error 4-18
 time interval measurement 4-6
 totalized count measurement 4-10
 trigger 3-6
 trigger error 4-16
 trigger level 3-6
 trigger level error 4-19
 trigger level timing error 4-19
 trigger mode 3-6
 TRIG key 3-7

U **Page**

units for measurement 1-6
 utility 5-10
 UTILITY key 5-10

